

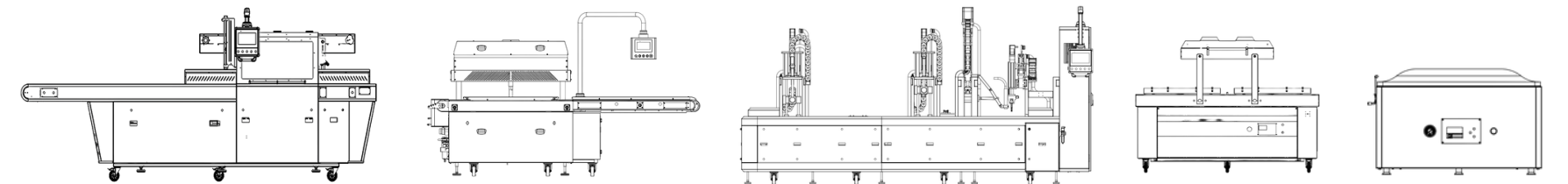

THE RIGHT WAY TO PACKAGE YOUR PRODUCTS

VOLVAC PACKAGING SOLUTIONS



INDEX

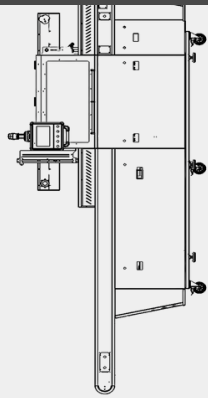

01

Our Vision

02

Our Mission

03

Machines

04

Machines

05

Packaging
Solutions

06

Type Of Packaging

07

Quality Control
Solutions

08

Why Choose
VOLVAC Vacuum
Packaging Systems?

09

Have You Set Up
Your Conveyor Line
With Volvac?

10

Volvac Advanced
Vacuum Packaging
System

11

Volvac Advanced
Vacuum Packaging
System

12

Volvac Advanced
Vacuum Packaging
System

13

Certificates

14

Volvac In World

15

Contact Us

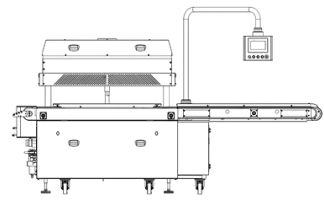

Our Vision



We are a success-oriented, minimalist company that always shows our clients the value they deserve!

At Volvac, our vision is to lead the packaging industry by delivering innovative, sustainable, and high-quality packaging solutions that meet the evolving needs of our global customers. We strive to create value through cutting-edge technology, environmental responsibility, and a commitment to excellence. Our aim is to be the preferred partner for businesses seeking reliable, efficient, and eco-friendly packaging that enhances product integrity while minimizing environmental impact. By embracing continuous improvement and fostering a culture of creativity and collaboration, we envision shaping a future where packaging solutions contribute positively to both the economy and the planet.



Our Mission

We provide innovative solutions for all the needs of food manufacturers.

At Volvac, our vision is to lead the packaging industry by delivering innovative, sustainable, and high-quality packaging solutions that meet the evolving needs of our global customers. We strive to create value through cutting-edge technology, environmental responsibility, and a commitment to excellence. Our aim is to be the preferred partner for businesses seeking reliable, efficient, and eco-friendly packaging that enhances product integrity while minimizing environmental impact. By embracing continuous improvement and fostering a culture of creativity and collaboration, we envision shaping a future where packaging solutions contribute positively to both the economy and the planet.

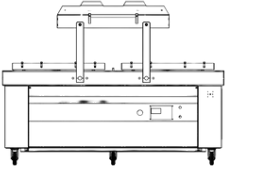

Machines

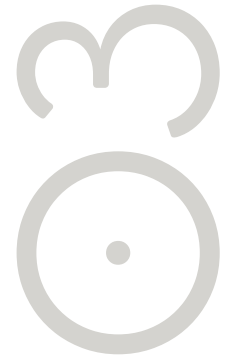
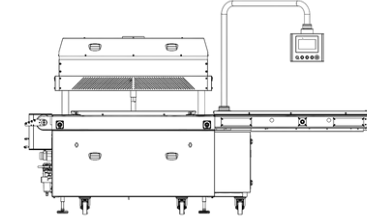

TRAY SEALER



VACUUM
PACKAGING



BOTTOM TANK
AND SHRINK
TUNNEL



AUTOMATIC
SLICING

Machines

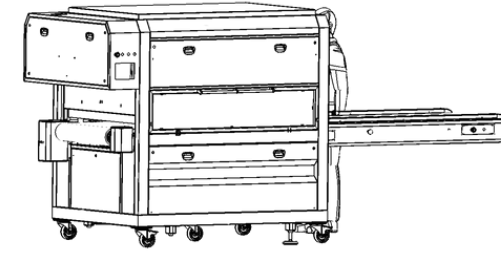

TRAY SEALER



**VACUUM
PACKAGING**



**BOTTOM TANK
AND SHRINK
TUNNEL**



**AUTOMATIC
SLICING**

Packaging Solutions

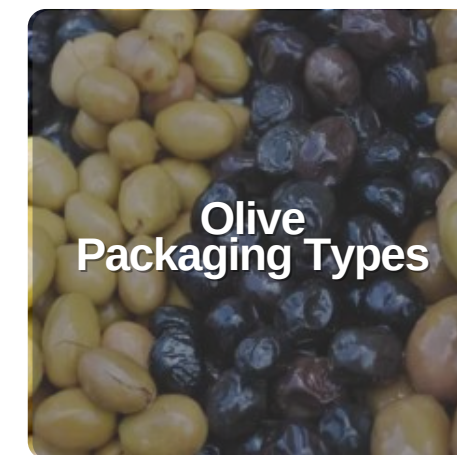
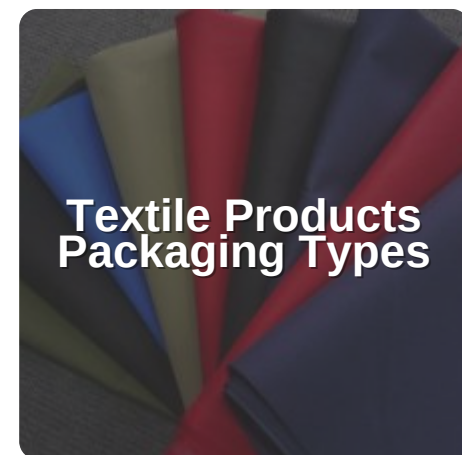
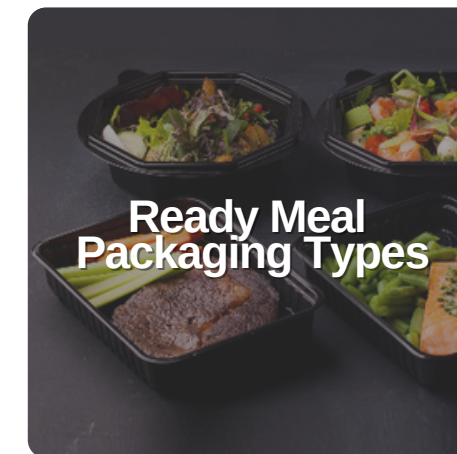
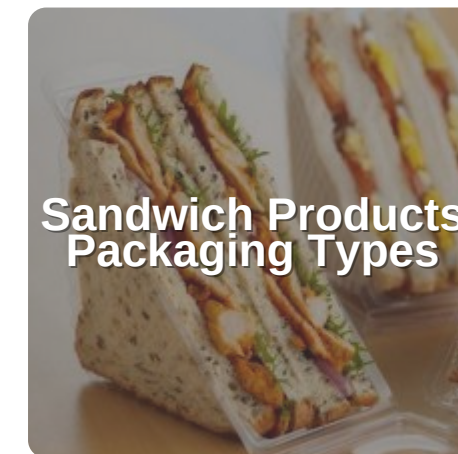
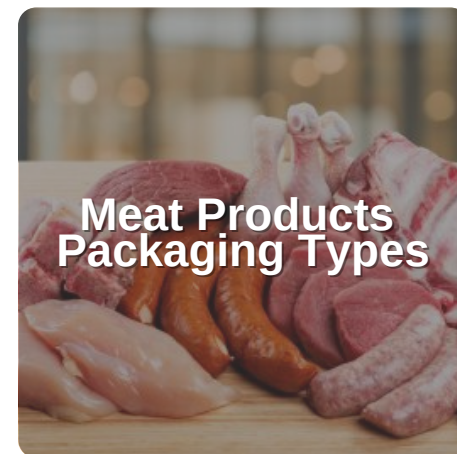

Type Of Packaging

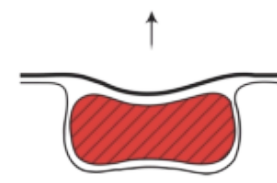

Only Vacuum

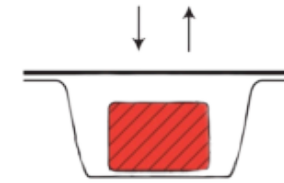

Sealing

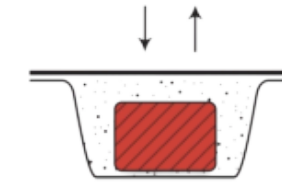

MAP

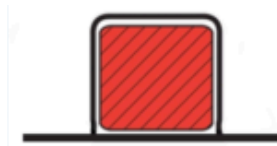

Cardboard Skinpack



Deep Skinpack



Skinpack

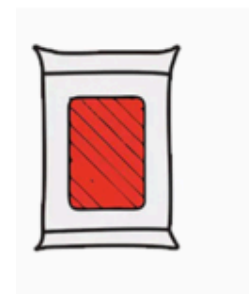

Vacuum



Sealing



Vacuum+Gas



Complete Vacuum Packaging & Quality Control Solutions



At VOLVAC, we specialize in high-performance vacuum packaging systems, offering a wide range of packaging technologies tailored to different industries. Our solutions include standard vacuum packaging, vacuum skin packaging (VSP) for an enhanced product display, modified atmosphere packaging (MAP) to extend freshness using gas mixtures, and shrink vacuum packaging for a tight, protective seal. Whether you're packaging fresh meat, seafood, cheese, liquids, or non-food products, VOLVAC's integrated systems ensure optimal preservation, safety, and efficiency. Our fully automated lines incorporate label applicators, check weighers, metal detectors, and more, creating a streamlined, high-quality packaging process that meets the highest industry standards.

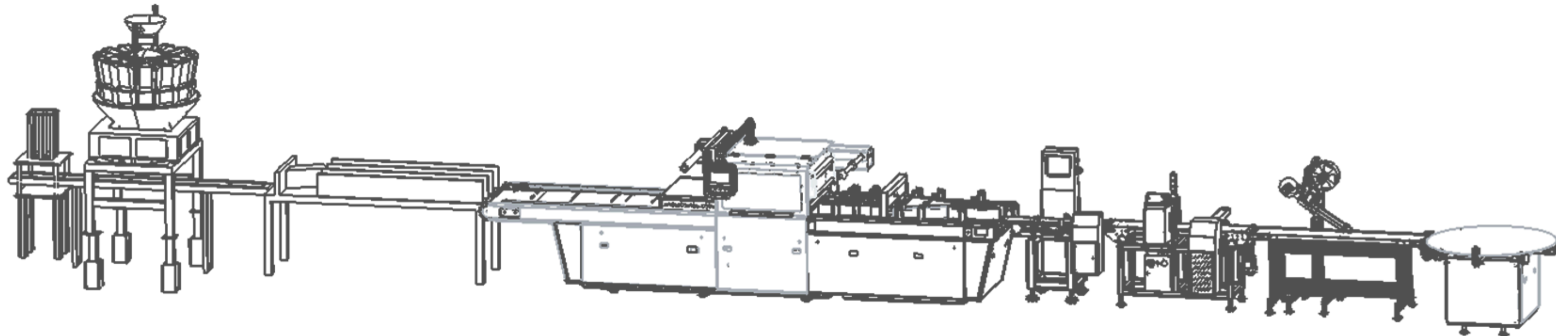

Why Choose VOLVAC Vacuum Packaging Systems?

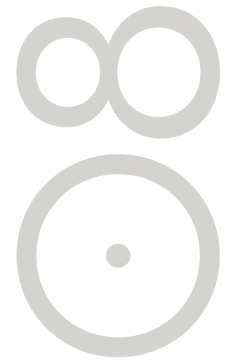

- ✓ Extended Shelf Life & Freshness – Our advanced vacuum technology ensures maximum product preservation.
- ✓ Seamless Integration & Automation – Optimized production workflows with intelligent, fully automated systems.
- ✓ Superior Food Safety & Compliance – Cutting-edge metal detection, weight verification, and contamination prevention.
- ✓ Enhanced Brand Presentation – High-quality sealing, labeling, and shrink packaging for a professional finish.
- ✓ Customizable Solutions – Tailored to your industry needs, product type, and production capacity.

Would you like a customized vacuum packaging line proposal for your specific production requirements?
Contact VOLVAC today to discuss the perfect solution for your business!

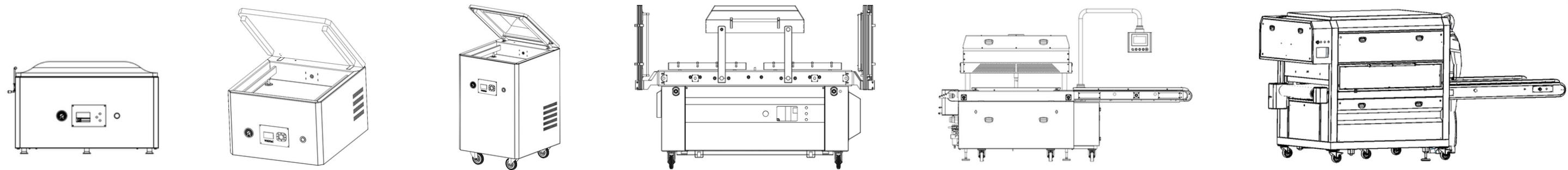



Have You Set Up Your Conveyor Line With Volvac?



Dry Tunnel



Shrink Tunnel



Metal Detector



L Conveyor

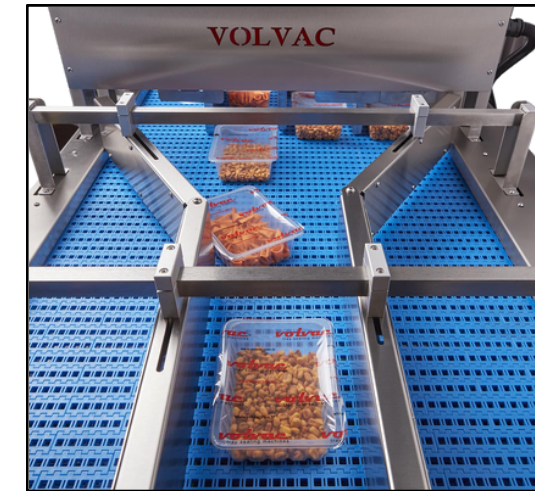

Sorting Conveyor



Label Applicator

Volvac Advanced Vacuum Packaging System



1. Precision Vacuum Packaging Technology

- **Product Loading & Preparation:** Products are manually or automatically placed into high-quality vacuum pouches or trays. The system supports automated feeding mechanisms for high-speed production lines.
- **Air Extraction & Sealing:** VOLVAC vacuum chambers efficiently remove 99.8% of air from the package, preventing oxidation, bacterial growth, and moisture loss. Liquid Control Technology ensures the safe packaging of liquid products. Modified Atmosphere Packaging (MAP) helps maintain product freshness, color, and texture. Vacuum Skin Packaging (VSP) wraps the product with a tight film, enhancing visibility and quality.
- **Heat Sealing:** Precision heat sealing technology ensures leak-proof and tamper-resistant packaging.
- **Cooling & Discharge:** After sealing, packages are cooled and smoothly discharged onto the conveyor for the next stage.

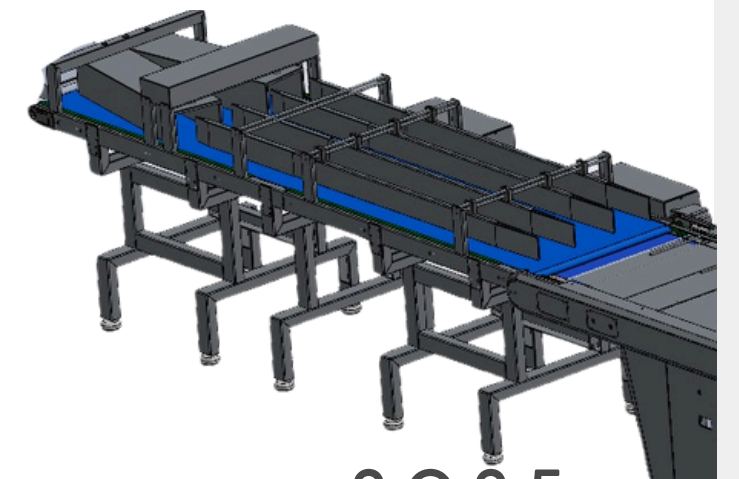
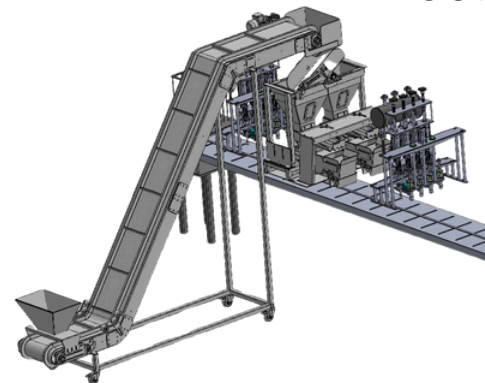



2. Integrated Quality Control & Automation

- Label Applicators: High-speed label applicators ensure every product is marked with brand logos, barcodes, expiration dates, and batch numbers.
- Check Weighers: Precision checkweighers automatically verify product weight and ensure compliance with regulations. Non-conforming packages are automatically separated.
- Metal Detectors & X-Ray Inspection: Metal detectors detect ferrous and non-ferrous metal contaminants. X-ray inspection technology detects glass, bone, plastic, and other foreign objects.
- Shrink Tanks & Drying Systems: Hot water shrink tanks ensure a professional finish for vacuum skin packaging (VSP), while drying units remove moisture before labeling.
- Conveyor & Sorting Systems: Automated conveyor belts enhance workflow efficiency, and sorting units automatically separate defective packages, ensuring only premium-quality products reach consumers.

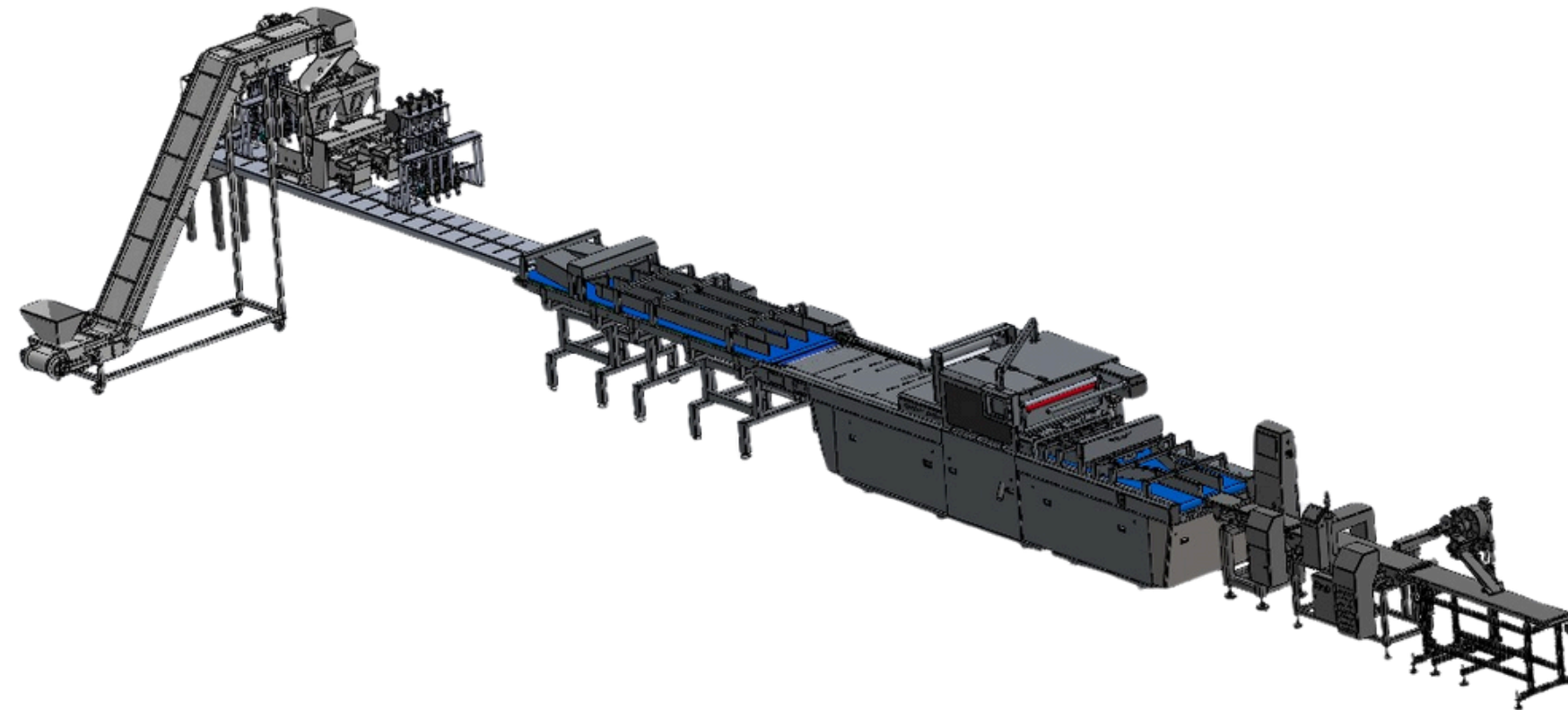

3. Final Packaging & Distribution Solutions

- Cartoning & Box Sealing Machines: Vacuum-sealed products are efficiently placed into cartons for storage and shipping.
- Palletizing Systems: Automated stacking and wrapping systems ensure large-scale distribution.
- Cold Storage & Logistics Optimization: Products are stored and transported under optimal conditions.



PTS83

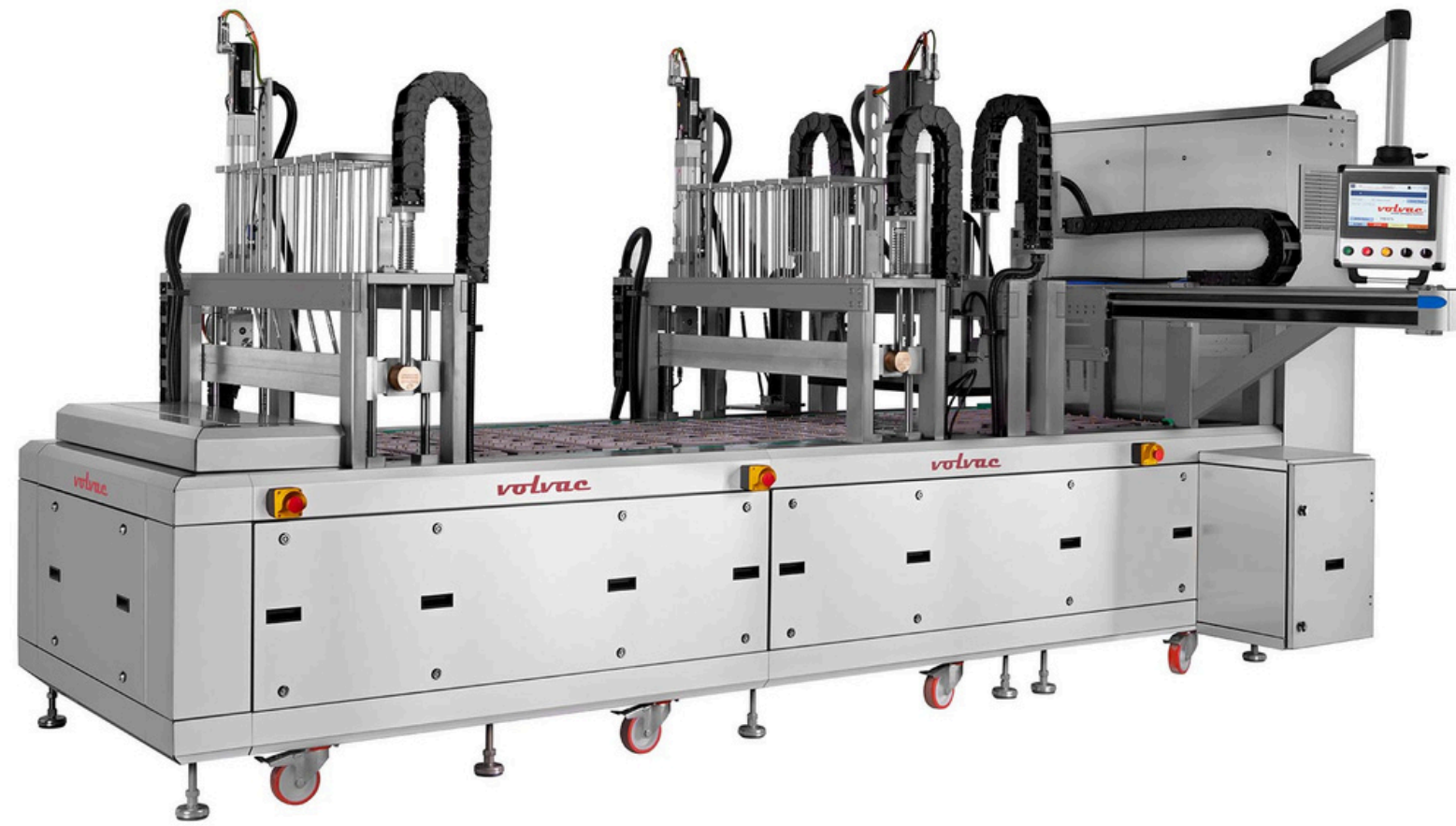

The PTS 83 is a high-performance machine designed to optimize production with its multi-filling system, offering flexible configurations from 1 to 4 fill points. Its compact structure (2809x4496xh2254 mm) supports both top roll and pre-cut film sealing, enhancing efficiency. Key features include an aluminum film denester, sealing unit, and robotic product discharge for full automation.

It ensures precision and safety with Schneider and Omron displays, and sensors from Leuze, Sick, and Carlo Gavazzi. The machine is powered by a Schneider AC servo motor system for continuous 24/7 operation. Capable of automatic tray filling, film wrapping, and MAP (vacuum gas packaging), it achieves a speed of 15-20 cycles per minute, combining speed with high quality for improved production efficiency.

TERMOFORM

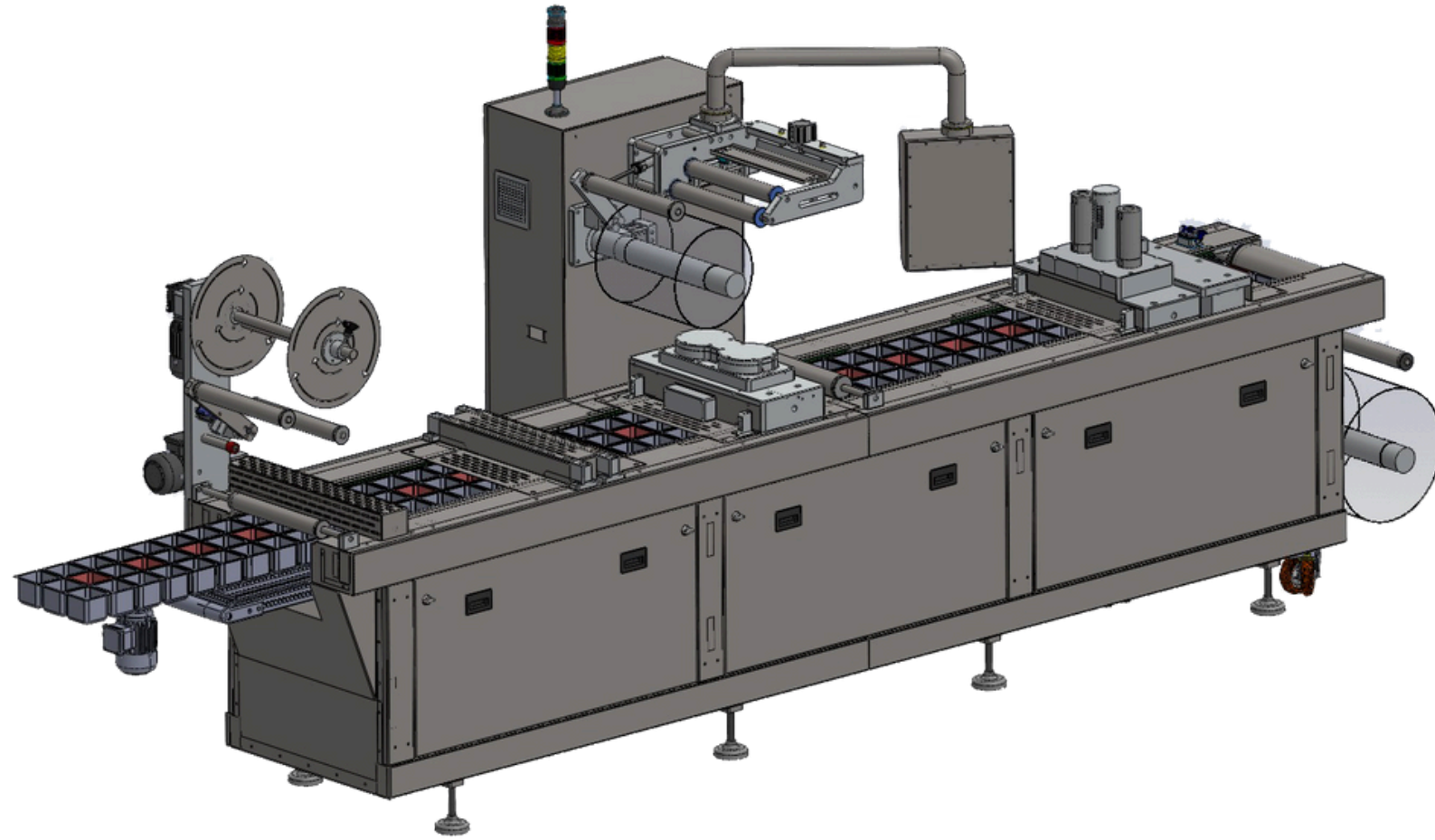

The W Series Fully Automatic Vacuum and MAP Applied Thermoforming Packaging Machine is a versatile solution that can meet various needs, performing all packaging processes and providing products with an extended shelf life.

It can be used in many different areas such as packaging dairy products, baked goods, meat products, medical products, ready-to-eat meals, and dried fruit and vegetable products. Additional Features that can be integrated: Travers unit, inkjet, labeling systems, control systems, scale.



Have You Set Up Your Conveyor Line With Volvac?



Dry Tunnel



Shrink Tunnel



Metal Detector



L Conveyor



Sorting Conveyor



Label Applicator

13

Certificates

We Certify Quality, We Sign for Trust!

As VOLVAC, we consider manufacturing in compliance with national and international standards as an integral part of our commitment to quality. All of our machines have quality and safety certifications that are valid worldwide, starting with CE. Our production facilities are audited according to ISO 9001 quality management standards, and all our processes are carried out in accordance with these high standards. Additionally, our machines undergo various certifications in accordance with industry requirements, and their quality and durability are verified through rigorous testing.

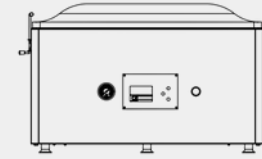

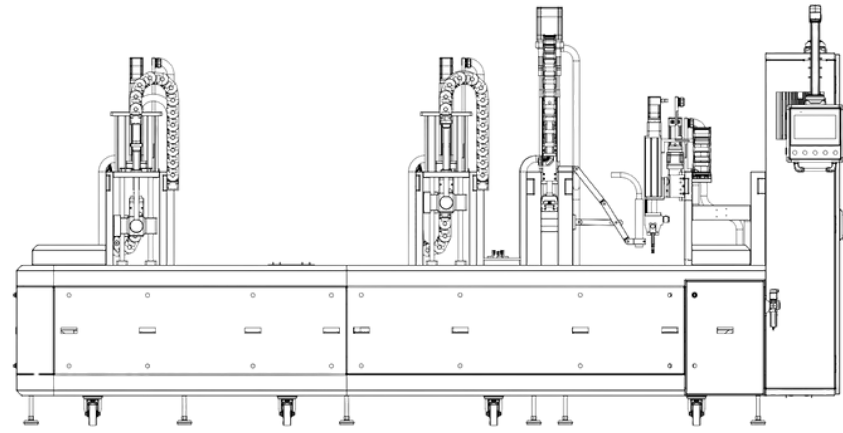

Contact Us

www.volvac.com.tr

51



Turkey Office
Showroom

Sanayi District
Ensar Street
No: 3/1
Kurtkoy, Pendik,
Istanbul, Türkiye

info@volvac.com.tr
+90 216 441 10 72



Turkey Factory

Sanayi District
Sanayi Street
No: 15/1
Kurtkoy, Pendik,
Istanbul, Türkiye

info@volvac.com.tr
+90 216 441 10 72



Germany Office

Ikarusallee
15, 30179
Hannover,
Almanya

info@volvacgermany.de
+49 163 263 39 94



Egypt Office

21 Gol Gamal
Str.
Mohandessein
Giza - Egypt

mr@volvaceg.com
+20 10 21108805

2025



Packaging solutions that add value to your brand!

We wish you all the best in your work.