

volvac
PACKAGING SOLUTIONS



**VACUUM & TRAY
SEALER MACHINES**



About Us



VOLVAC: A Global Leader in Vacuum Packaging & Tray Sealing Solutions

As a proud representative of Turkey, VOLVAC has successfully combined advanced technology with the strength of domestic production to emerge as a globally recognized brand in vacuum packaging and tray sealing machine manufacturing. With 18 years of expertise in the packaging and food machinery sector, VOLVAC has established a strong presence in strategic markets, including the USA, Russia, China, Germany, France, Israel, Pakistan, Ukraine, and Egypt, effectively positioning Turkey on the global stage.

Industry Leadership & Diverse Product Portfolio

VOLVAC sets itself apart in the industry with a comprehensive product portfolio, featuring vacuum packaging machines, tray sealing machines, dip tank machines, shrink & drying tunnels, and slicing machines. These machines, continuously enhanced through cutting-edge R&D efforts, are designed and manufactured to meet global standards. Produced at VOLVAC's state-of-the-art facility in Istanbul, each machine undergoes ISO-certified manufacturing and holds CE and other international quality certifications, ensuring top-tier reliability and performance.

Strategically located near Sabiha Gökçen Airport, VOLVAC operates with a focus on speed, efficiency, and precision, ensuring prompt and accurate responses to customer demands.

Commitment to Quality & International Standards

VOLVAC maintains an unwavering commitment to quality and competitive pricing, ensuring the highest levels of customer satisfaction. Whether manufacturing its own equipment or importing specialized food processing machinery, the company leads the sector by utilizing local resources and suppliers to produce machines that adhere to international standards. Every machine undergoes rigorous CE and ISO-compliant quality assurance testing before being released to the market.

Situated in Pendik/Kurtköy, just five minutes from the Istanbul Ring Road (O6) and Sabiha Gökçen Airport, VOLVAC's modern manufacturing facility is a testament to its competitive strength in the global marketplace.

Global Reach & Customer-Centric Approach

With exports to over 42 countries, VOLVAC is dedicated to excellence in both product quality and after-sales support. Its extensive product range, including vacuum packaging machines, plate and bowl sealing machines, dip tank machines, and slicing machines, is readily available from stock to ensure timely delivery. Supported by continuous R&D investments, VOLVAC's machines are manufactured with precision CNC technology, offering exceptional performance and easy maintenance.

Operating with a zero-error approach in machine quality and backed by a customer-first philosophy, VOLVAC remains at the forefront of the packaging industry, driving innovation and setting new standards for reliability and efficiency worldwide.

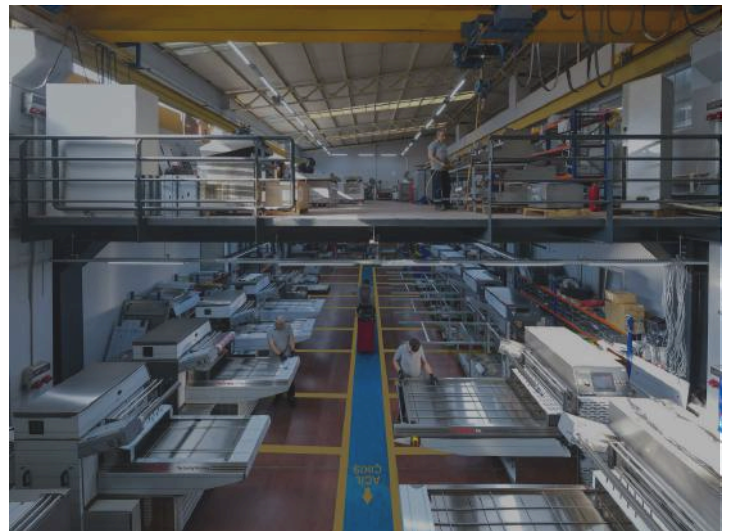

Certificates



Packaging Solutions

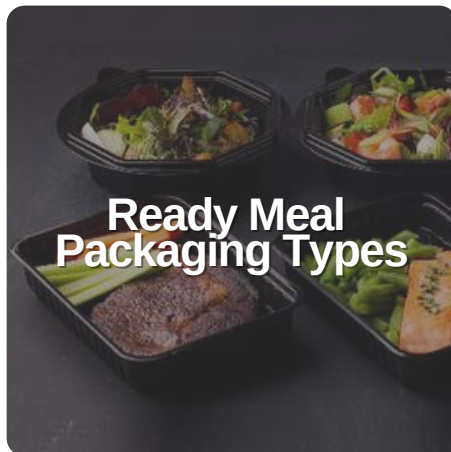

Index

- ✓ Tray Sealing Machines
- ✓ Skinpack Machines
- ✓ Termoform Machines
- ✓ Vacuum Packaging Machines
- ✓ Dip Tank Machines
- ✓ Automatic Slicer Machine





**TRAY SEALING
MACHINES**



✓ Full Automatic Models
(PTS83, E42 PRO, E35 PRO, E30 PRO, E42, E35, E30)

✓ Rotary Models
(AXIS)

✓ Drawers Models
(E52, E26, TS40, TS52)

✓ Semi Automatic Models
(W850VG, W650VG, W450VG)

✓ Manual Models
(TS350, TS450)



Full Automatic Models **PTS83**

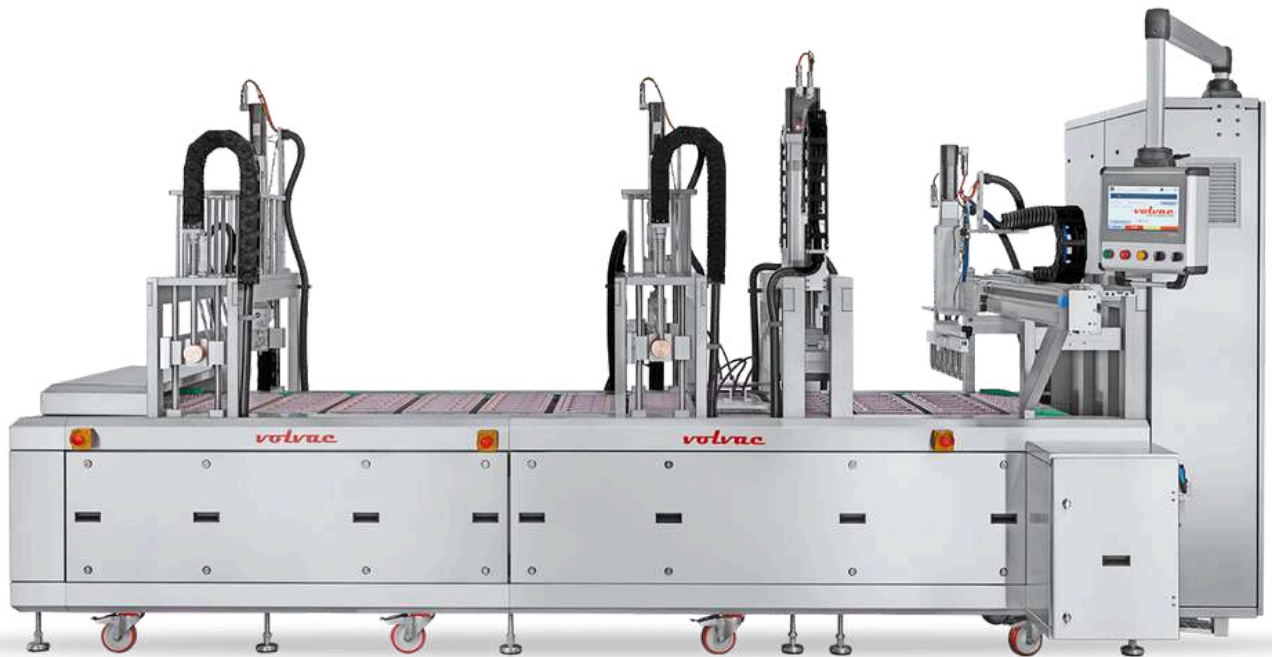

Machine Dimensions : 2809x4496xh2254 mm

Pump Capacity : 150 m³ (Option 200 m³, 300 m³/h)

Cycle: 15-20 Cycles Per Minute

Electric & PLC System: SCHINEIDER / OMRON

Maximum Tray Height: 110 mm

Safety Sensors: Leuze Sick and Carlo Gavazzi Sensor

Motor & Encoder System: Schneider Servo Motor

Operating Time: 24 Hour Continuous Operation

Outer Body : Stainless Steel AISI304 and Aluminum

Warranty : 2 Years

Certificate: CE

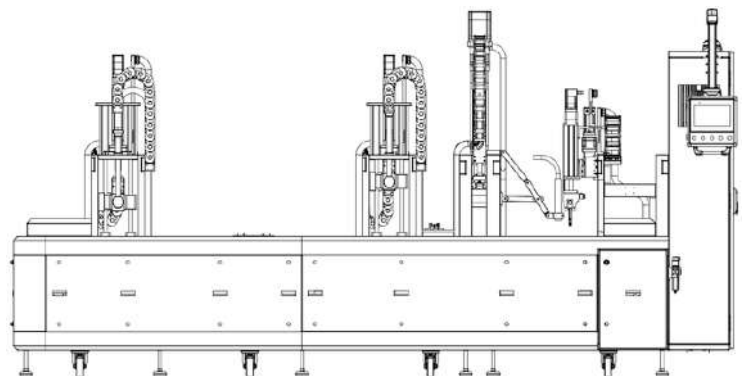
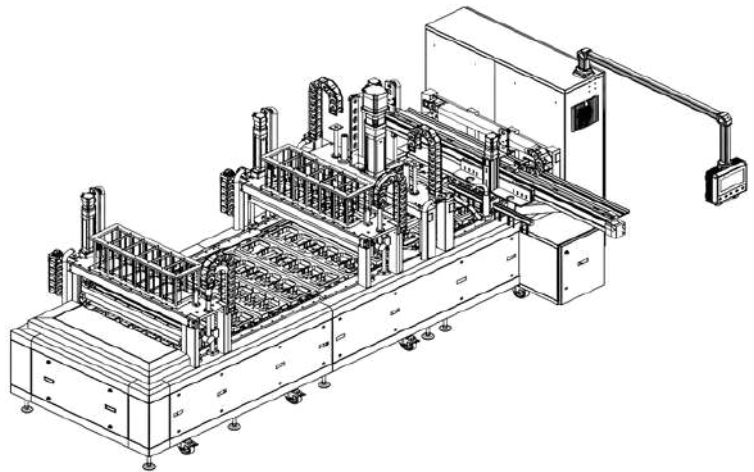



- Machine Dimensions : 1653 x 4438 x 1837 h mm
- Pump Capacity : 300 m³ / h (100 m³ - 150 m³ - 200 m³)
- Cycle: 3-10 cycles/minute
- Pneumatic System:: SMC/FESTO
- Voltage : 3P+N+PE 380V 50Hz
- KW : 5.5kW - 7kW - 9kW - 12kW
- PLC System: SCHINEIDER / OMRON
- Max Roll Width : 710mm
- Outer Body : Stainless Steel AISI304
- Warranty : 2 Years
- Certificate: CE

325x265		190x144		227x178	

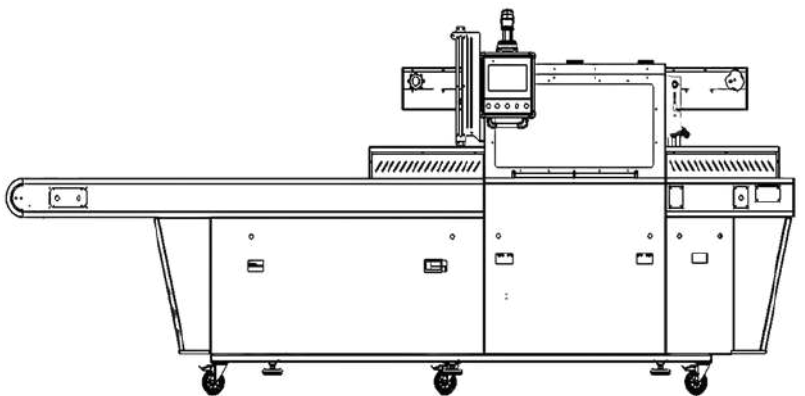

Full Automatic Models **E35 PRO**



- **Machine Dimensions :** 1710 x 3680 x 1850 h mm
- **Pump Capacity :** 100 m³ / h (150 m³ - 200 m³ - 300 m³)
- **Cycle:** 3-10 cycles/minute
- **Pneumatic System:** SMC/FESTO
- **Voltage :** 3P+N+PE 380V 50Hz
- **kW:** 5.5 kW - 7kW - 9kW - 12kW
- **PLC System:** SCHNEIDER / OMRON
- **Max Roll Width :** 710mm
- **Outer Body :** Stainless Steel AISI304
- **Warranty :** 2 years
- **Certificate:** CE

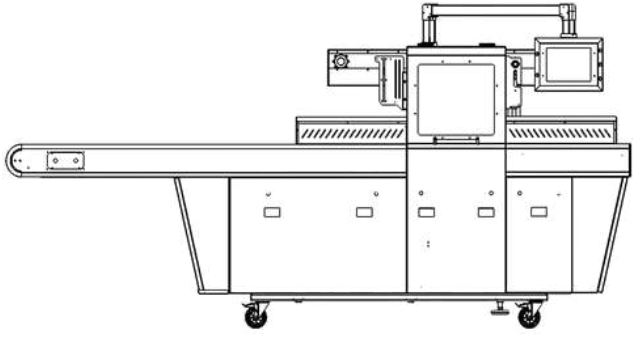
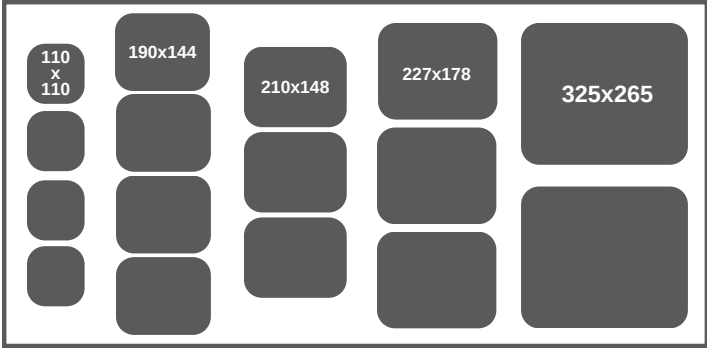



Machine Dimensions : 1413x3169x1837mm

Pump Capacity : 100 m³/h (150 m³ - 200 m³ - 300 m³)

Cycle: 3-10 cycles / minute

Pneumatic System: SMC/FESTO

Voltage : 3P+N+PE 380V 50Hz

kW: 5.5 kW - 7kW - 9kW - 12kW

PLC System: SCHNEIDER / OMRON

Max Roll Width : 450mm

Outer Body : Stainless Steel AISI304

Warranty : 3 Years

Certificate: CE

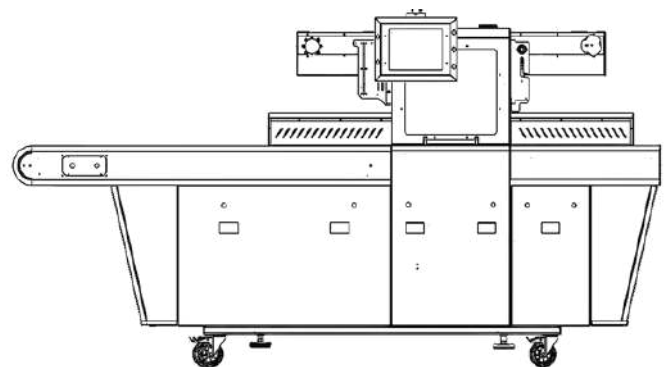
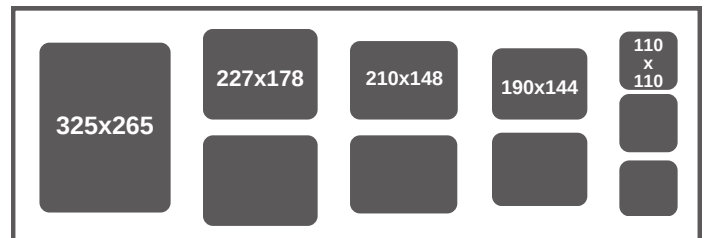

Full Automatic Models **E42**



Machine Dimensions :1245 x 4255 x 1780 h mm

Pump Capacity :300 m³ / h (100 m³ - 150 m³ - 200 m³)

Cycle: 3 - 10 cycles/minute

Pneumatic System: SMC/FESTO

Voltage : 3P+N+PE 380V 50Hz

kW: 5.5kW - 7kW - 9kW - 12kW

PLC System: SCHNEIDER / OMRON

Max Roll Width : 720 mm

Outer Body : Stainless Steel AISI304

Warranty : 2 Years

Certificate: CE

325x265		227 x 178		210 x 148	

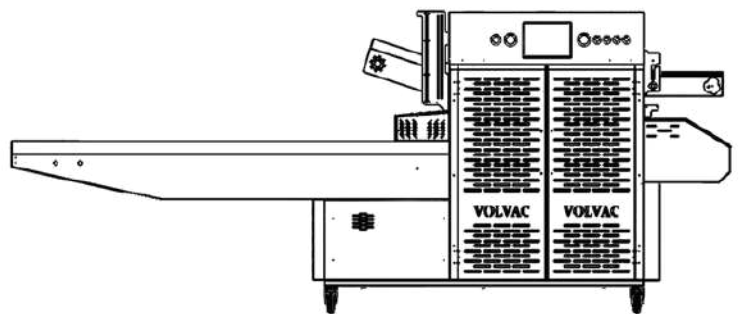

Full Automatic Models E35



- ▶ Machine Dimensions : 1170 x 3600 x 1780 h mm
- ▶ Pump Capacity : 100 m³ / h (150 m³ - 200 m³ - 300 m³)
- ▶ Cycle: 3 - 10 cycles/minute
- ▶ Pneumatic System: SMC/FESTO
- ▶ Voltage : 3P+N+PE 380V 50Hz
- ▶ kW: 5.5 kW - 7kW - 9kW - 12kW
- ▶ PLC System: SCHNEIDER / OMRON
- ▶ Max Roll Width : 720 mm
- ▶ Outer Body : Stainless Steel AISI304
- ▶ Warranty : 2 Years
- ▶ Certificate: CE

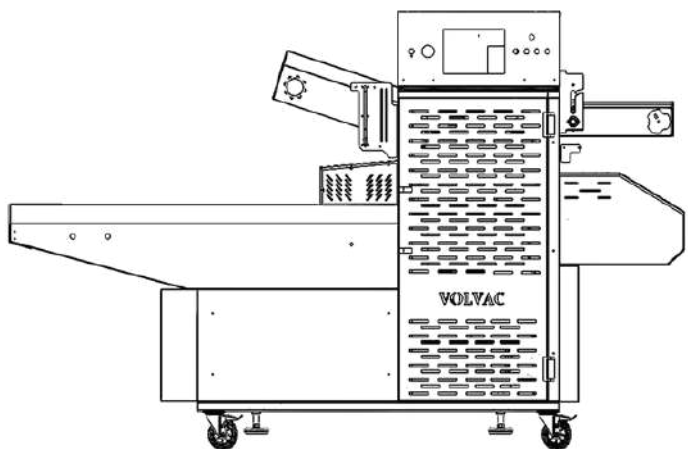
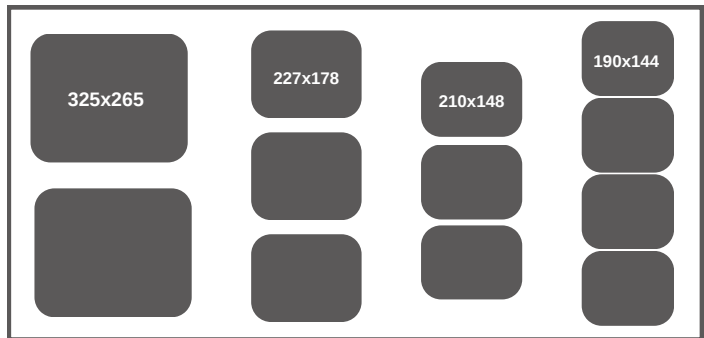

Full Automatic Models E30



Machine Dimensions : 900 x 2890 x 1830 h mm

Pump Capacity: 100 m³ / h (150 m³ - 200 m³ - 300 m³)

Cycle: 3 - 10 cycles/minute

Pneumatic System: SMC/FESTO

Voltage : 3P+N+PE 380V 50Hz

kW: 5.5 - 7 kW - 9kW - 12kW

PLC System: SCHNEIDER / OMRON

Max Roll Width : 460 mm

Outer Body : Stainless Steel AISI304

Warranty : 2 Years

Certificate: CE

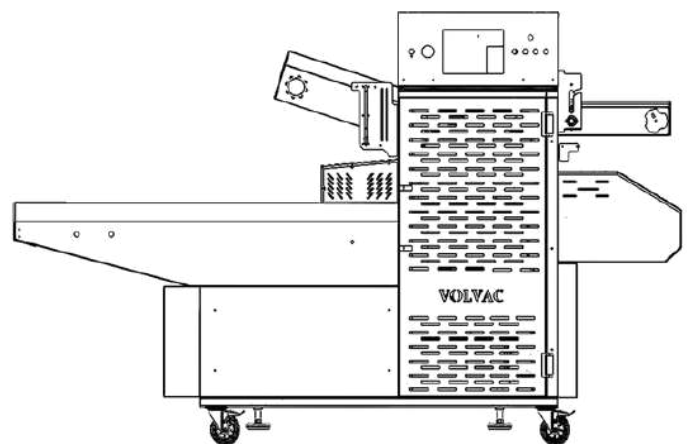
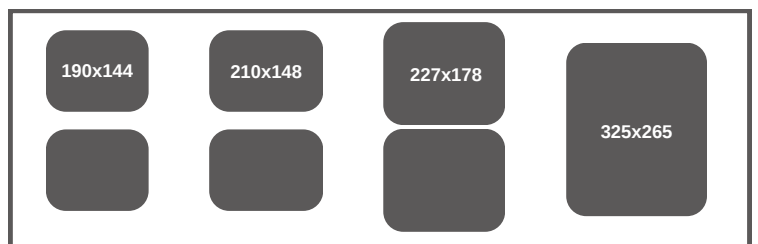



Machine Dimensions : 1555 x 1445 x 1810 h mm

Pump Capacity : 105 m³/h

Cycle: 3-7 cycle/minutes (Vacuum+Gas)

PLC System: SCHNEIDER / OMRON

Voltage : 380V- 45A- 50 Hz, 3P+N+PE

kW: 5 kW

Pneumatic Feeding : 16 NI/6-8 bar

Upper Film Width: 450 mm

Outer Body : Stainless Steel AISI304

Warranty : 2 Years

Certificate: CE

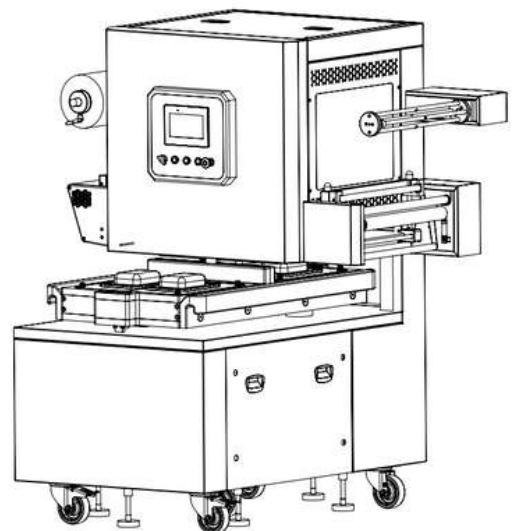

Drawers Models E52



Machine Dimensions : 1500 x 950 x 1450 h mm

Pump Capacity : 100 m³ / h (150 m³ Opt.)

Cycle: 4– 5 cycle/minute

PLC System: SCHINEIDER / OMRON

Voltage : 240 V 50Hz

kW: 5 kW

Pneumatic Feeding : 16 NI/6-8 bar

Max Roll Width : 470mm

Outer Body : Stainless Steel AISI304

Warranty : 2 Years

Certificate: CE

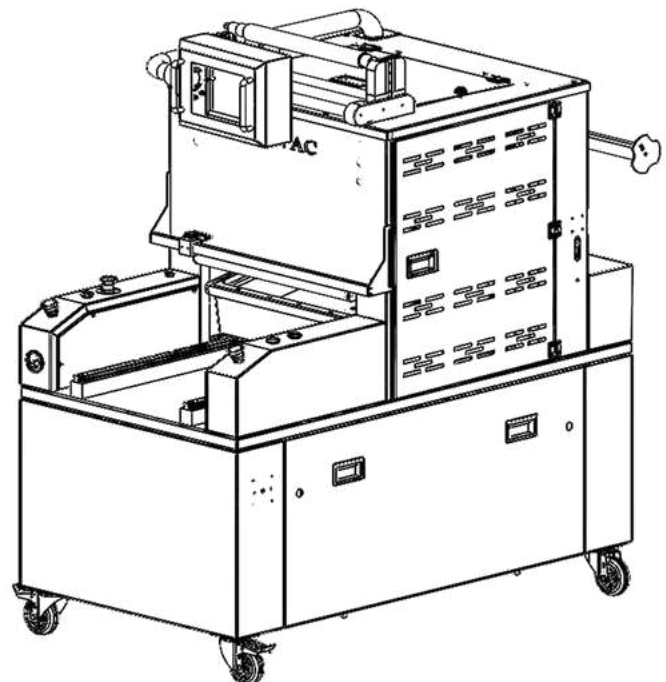
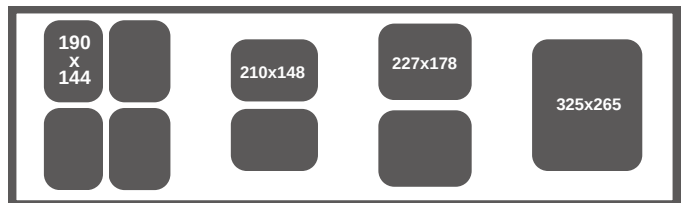



- Machine Dimensions :** 732 x 1060 x 752 h mm
- Pump Capacity :** 21 m³ / h (45 m³ Opt.)
- Cycle:** 4-5 cycle/minute
- Weight:** 180 kg
- Voltage :** 230/380V
- kW:** 2kW / 4kW
- Pneumatic Feeding :** 16 NI/6-8 bar
- Max Roll Width :** 450mm
- Outer Body :** Stainless Steel AISI304
- Warranty :** 2 Years
- Certificate:** CE

190x144	210x148	227x178	325x265

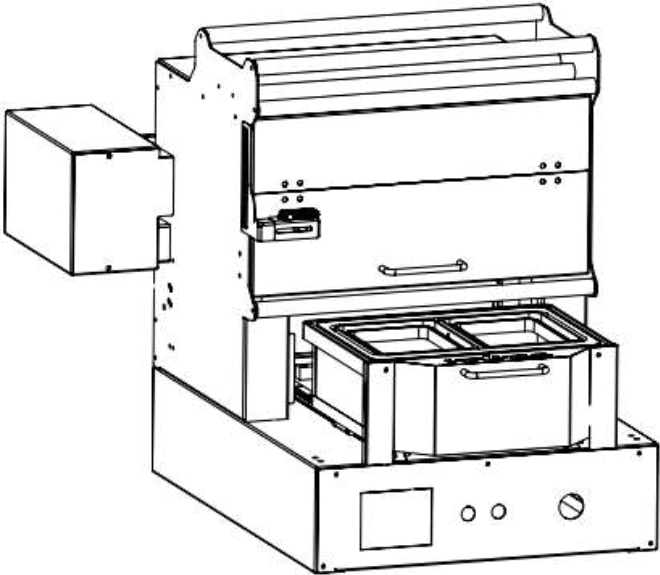

Semi Automatic Models **W850VG**



- Machine Dimensions : 740 x 767 x 1482 h mm
- Pump Capacity : 45 m³ / h (65 m³ Opt.)
- Cycle: 2 cycle/minute
- Mold System: Changeable Mold System
- Voltage : 3P+N+PE 380V 50Hz
- kW: 3 kW
- Pneumatic Feeding : 16 NI/6-8 bar
- Max Roll Width : 560 mm
- Outer Body : Stainless Steel AISI304
- Warranty : 2 Years
- Certificate : CE

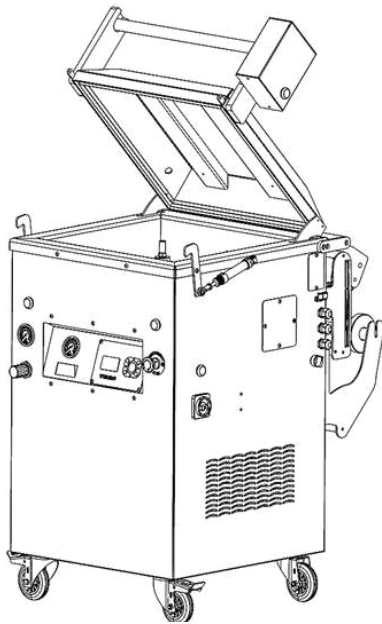
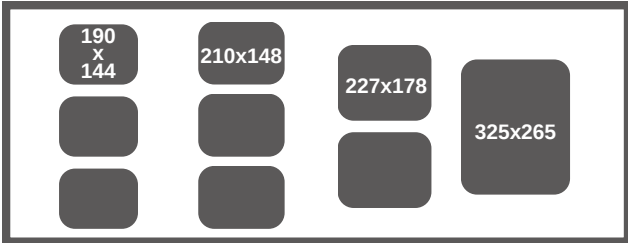

Semi Automatic Models **W650VG**



Machine Dimensions : 840 x 667 x 1482 h mm

Pump Capacity : 45 m³ / h (65 m³ Opt.)

Cycle: 2 cycle/minute

Mold System: Changeable Mold System

Voltage : 3P+N+PE 380V 50Hz

kW: 3 kW

Pneumatic Feeding : 16 NI/6-8 bar

Max Roll Width : 560mm

Outer Body : Stainless Steel AISI304

Warranty : 2 Years

Certificate: CE

190
X
144

210x148

227x178

325x265

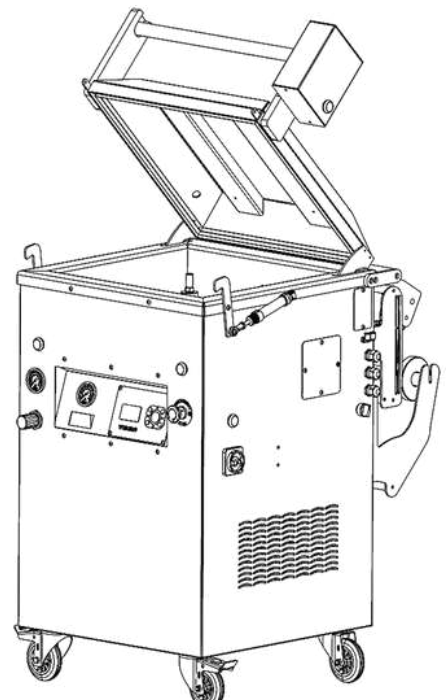

Semi Automatic Models **W450VG**



- Machine Dimensions : 740 x 667 x 1482 h mm
- Pump Capacity : 21 m³ / h
- Cycle: 2 cycle/minute
- Mold System: Changeable Mold System
- Voltage : 230v
- kW: 2.2 kW
- Pneumatic Feeding : 16 NI/6-8 bar
- Max Roll Width : 470mm
- Outer Body : Stainless Steel AISI304
- Warranty : 2 Years
- Certificate: CE

110 x 110		190x144	210x148	227x178	
					325x265

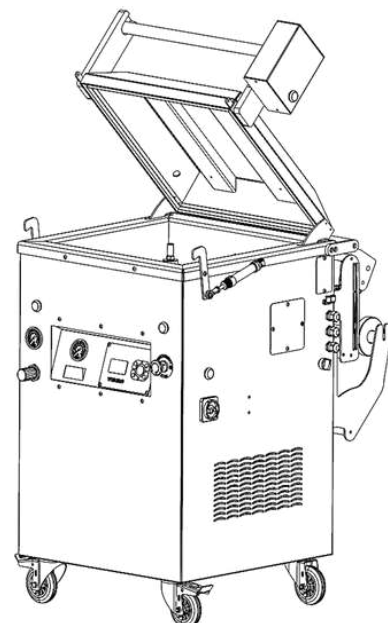



Machine Dimensions : 1050 x 800 x 600 h mm

Pump Capacity : 440 x 280 mm

Cycle: 10 -12 cycle/minute

Mold System: Changeable Mold System

Voltage : 3P+N+PE 380V 50Hz

kW: 1.5 kW

Pneumatic Feeding : 16 NI/6-8 bar

Max Roll Width : 430mm

Outer Body : Stainless Steel AISI304

Warranty : 2 Years

Certificate: CE

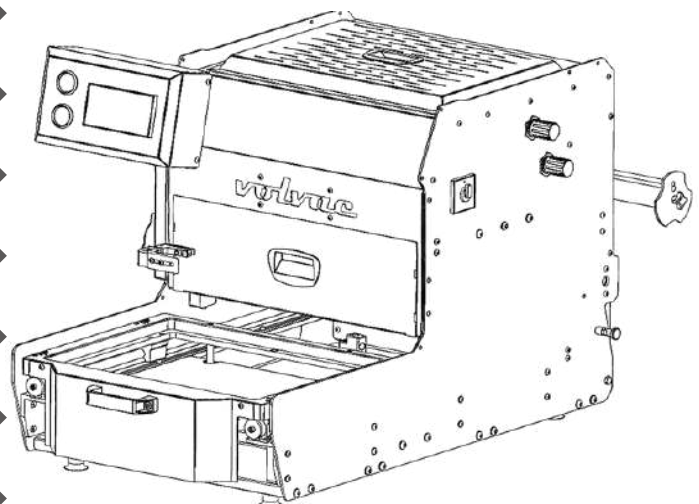
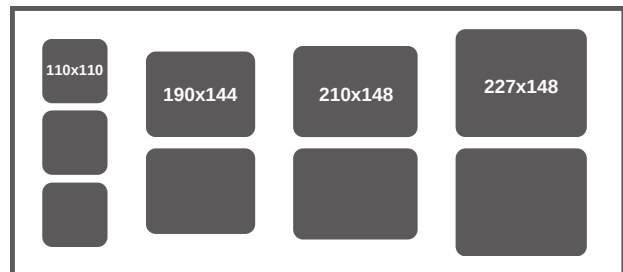

Drawers Models **TS52**



Machine Dimensions : 1250 x 900 x 750 h mm

Pump Capacity : 100m³ / 150m³

Cycle: 10 – 12 cycle/minute

Mold System: Changeable Mold System

Voltage : 3P+N+PE 380V 50Hz

kW : 1.5 kW

Pneumatic Feeding : 16 NI/6-8 bar

Max Roll Width : 450mm

Outer Body : Stainless Steel AISI304

Warranty : 2 Years

Certificate: CE

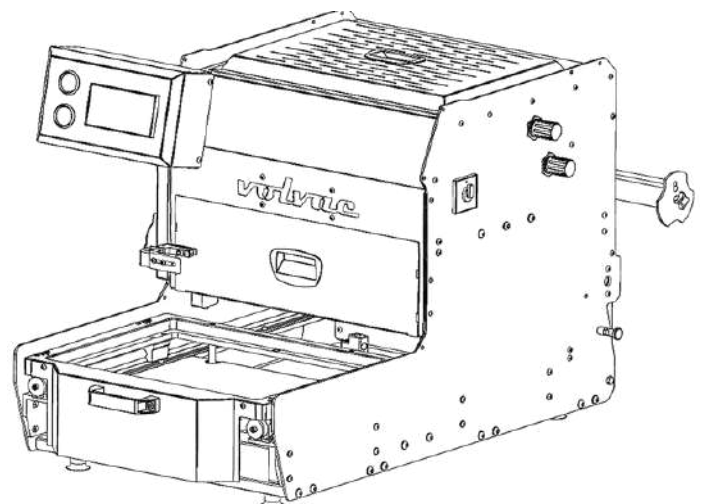
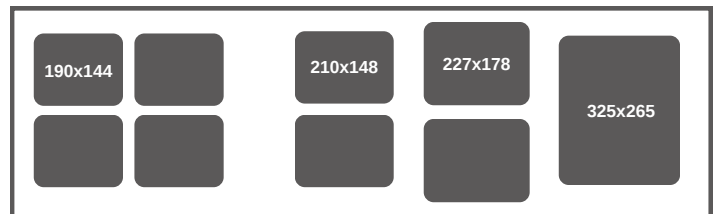



- Machine Dimensions : 465 x 352 x 320 h mm
- Capacity : 3 seconds average
- Voltage : 230 V
- kW : 1 kW
- Pneumatic Feeding : 16 NI/6-8 bar
- Max Roll Width : 270mm
- Outer Body : Stainless Steel AISI304
- Warranty : 2 Years
- Certificate: CE

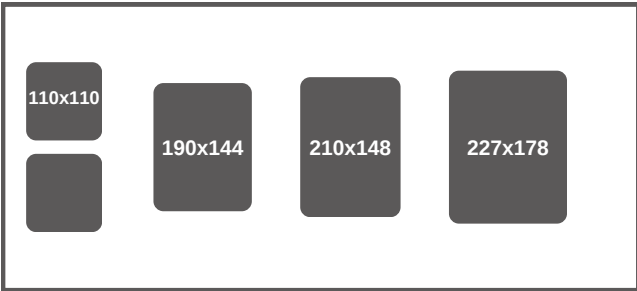

Manual Models TS450



Machine Dimensions : 465 x 465 x 320 h mm

Capacity : 900 plate per a hour

Voltage : 230 V

kW : 1kW

Pneumatic Feeding : 16 NI/6-8 bar

Max Roll Width : 270mm

Outer Body : Stainless Steel AISI304

Warranty : 2 Years

Certificate: CE

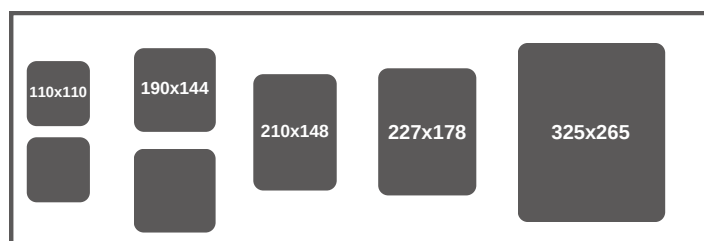

Type Of Packaging Solutions

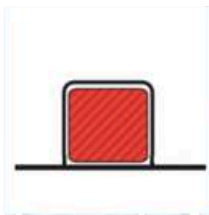

Cardboard Skinpack



Deep Skinpack

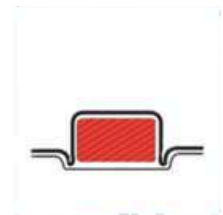

Skinpack

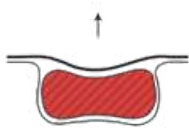

Vacuum MAP

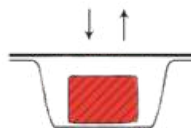

Sealing

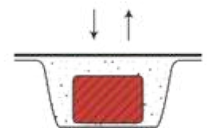

MAP



volvac

Skinpack Machines

Skinpack packaging solutions that provide long shelf life.



Cardboard Skinpack



Deep Skinpack



Skinpack





What can be packaged with

Skinpack Machines?

Tray Sealing Machines are packaging machines commonly used in the food industry and offer ideal solutions for a wide range of products. By using food-grade gases during packaging, they extend the shelf life of the packaged foods.

- Meat and Meat Products
- Cheese and Dairy Products
- Seafood Products
- Fruits and Vegetables
- Ready-to-Eat Meals
- Sweets and Chocolates
- Baked Goods
- Industrial and Medical Products





TERMOFORM MACHINES



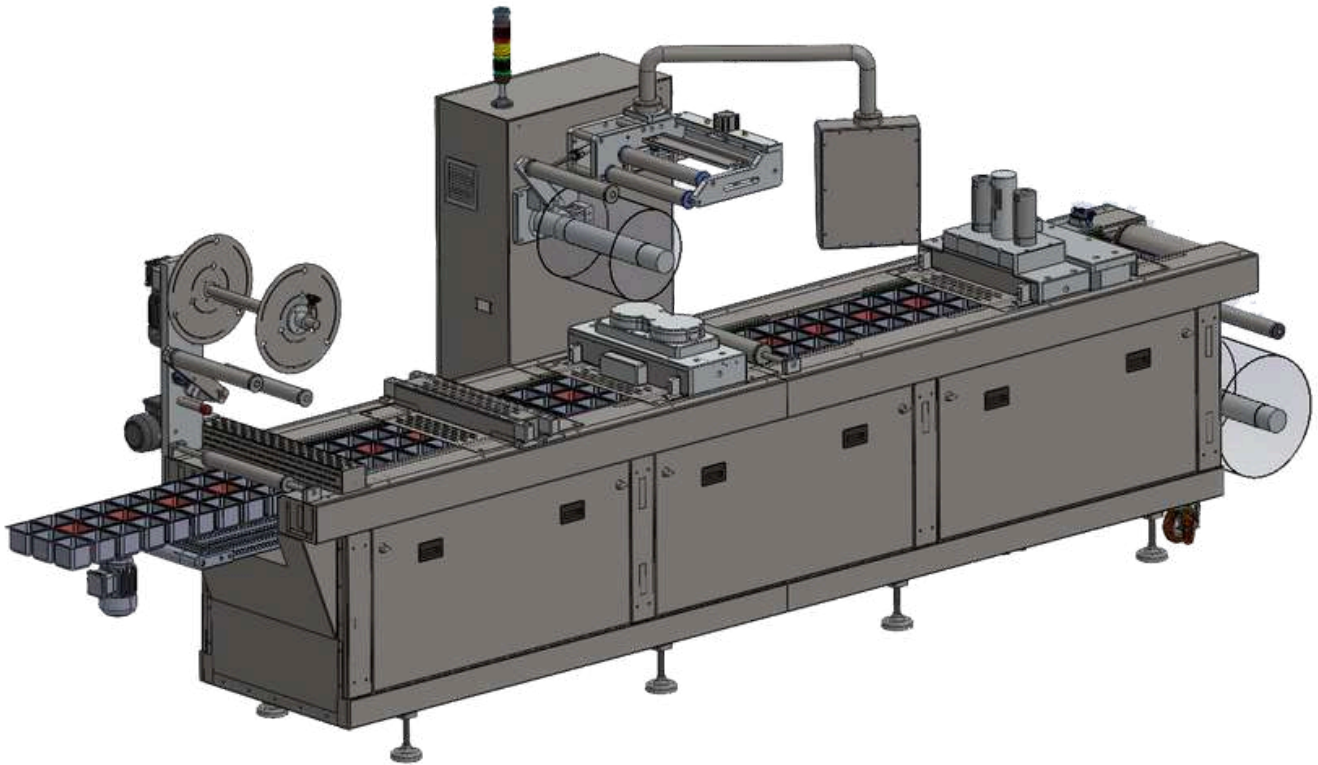

Machine Length : 3000mm – 15000mm

Forming Depth: 85mm. /150mm.

Reel Core Diameter: 2×300 (600m³)

Reel Diameter: 400mm - 300mm

PLC System: SCHNEIDER / OMRON

Pitch: 100 mm – 600mm

Top Film: (PA+PE)

Bottom Film: (PA+PE) / (PVC+PE) / (PET+PE)

Outer Body : Stainless Steel AISI304

Warranty : 2 Years

Certificate: CE

A top-down view of various fresh meats and vegetables packaged in clear vacuum bags, arranged on a dark, textured wooden surface. The items include a large piece of red meat (possibly beef or lamb), a salmon fillet with a lemon slice, a whole cooked shrimp, a piece of white fish, and a piece of yellowish meat. Fresh vegetables like broccoli, snap peas, and carrot sticks are scattered around the packages. A red square is visible on the left side of the image.

VACUUM PACKAGING MACHINES



 **Conveyor Vacuum Machine**
(W110C, W135C, SHRINK TUNNEL, DRY TUNNEL)

 **Double Chamber Models**
(W100, W86, W72, W55)

 **Floor Standing Models**
(W104, W68, W52, W51H, W48H)

 **Table Top Models**
(W51XL, W51, W48, W42, W35ML)

 **Vertical Models**
(W700)



Conveyor Model **W110C**



Machine Dimensions : 1320 x 3365 x 2000 h mm

Chamber Size : 1225 x 1070 x 220 h mm

Pump Capacity : 2x300 (600m³)

Sealing Jaw Length: 1100mm

PLC System: SCHNEIDER / OMRON

kW: 20 kW

Weight : 1800 kg

Closing Operation : 15-25 seconds

Outer Body : Stainless Steel AISI304

Warranty : 2 Years

Certificate: CE

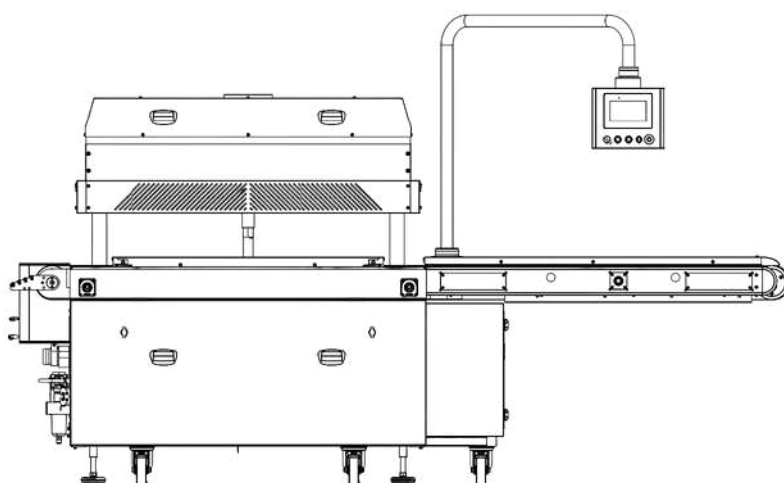

In case Shrink Tunnel and Drying Tunnel are purchased separately from the main machine, an optional control panel is available.

Conveyor Model **W135C**



Machine Dimensions : 1320 x 4130 x 2000 h mm

Chamber Size : 1500 x 1075 x 220 h mm

Pump Capacity : 2x300 (600m³)

Sealing Jaw Length: 1350mm

PLC System: SCHNEIDER / OMRON

kW: 20 kW

Weight : 2000 kg

Closing Operation : 15 - 25 seconds

Outer Body : Stainless Steel AISI304

Warranty : 2 Years

Certificate: CE

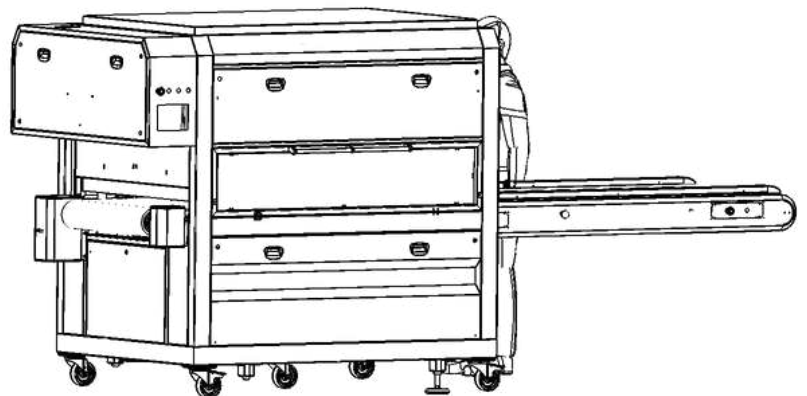

In case Shrink Tunnel and Drying Tunnel are purchased separately from the main machine, an optional control panel is available.

Conveyor Model **SHRINK TUNNEL**



Machine Dimensions :1500mmx1200mmx1600mm

Hot Water Spraying: Top and Bottom

Control Panel: Schneider

Conveyor Dimensions:770x1200

Conveyor Belt: Removable, Wire

kW: 35 kW

Conveyor Speed: Adjustable

Protection Class: IP63

Outer Body : Stainless Steel AISI304

Warranty : 2 Years

Certificate: CE

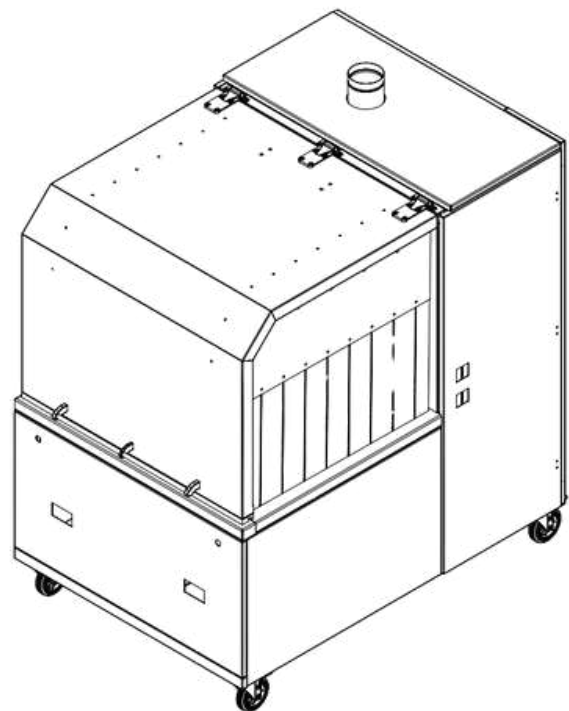

In case Shrink Tunnel and Drying Tunnel are purchased separately from the main machine, an optional control panel is available.

Conveyor Model **DRY TUNNEL**



Machine Dimensions :1500mmx1200mmx1600mm

Hot Water Spraying: Top and Bottom

Control Panel: Schneider

Conveyor Dimensions:770x1200

Conveyor Belt: Removable, Wire

kW: 35 kW

Conveyor Speed: Adjustable

Blowing System: 8 kW

Outer Body : Stainless Steel AISI304

Warranty : 2 Years

Certificate: CE

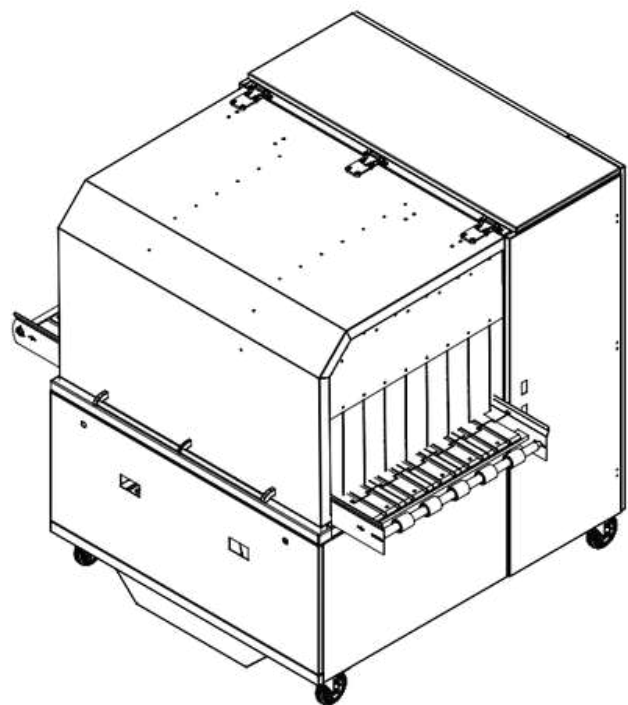

In case Shrink Tunnel and Drying Tunnel are purchased separately from the main machine, an optional control panel is available.

Double Chamber Models **W100**



Machine Dimensions : 2425 x 1140 x 1100 h mm

Chamber Size : 1225 x 950 x 220 h mm

Pump Capacity : 300 m³ / h

Sealing Bar : 4 x 1000 mm

Power : 3P+N+PE 380V 50Hz

kW : 9 - 11 kW

Weight : 750 kg

Closing Operation : 15 - 25 seconds

Outer Body : Stainless Steel AISI304

Warranty : 2 Years

Certificate: CE

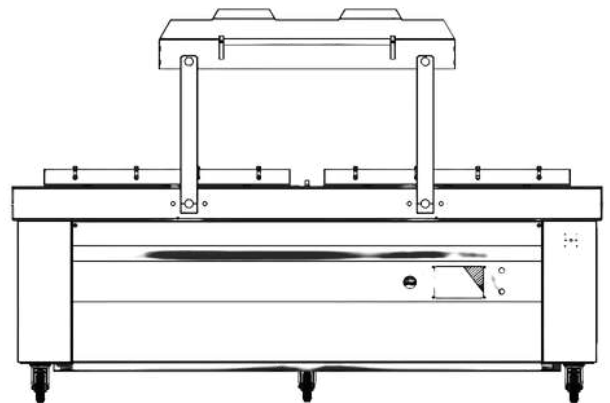
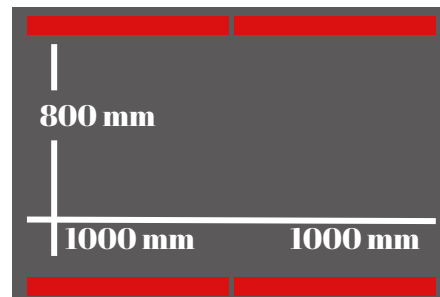

Double Chamber Models W86



Machine Dimensions : 1065 x 2080 x 1100 h mm

Chamber Size : 860 x 1000 x 220 h mm

Pump Capacity : 200 m³ / h (300 m³ Opt.)

Sealing Bar : 4 x 860 mm

Power : 3P+N+PE 380V 50Hz

kW : 8 - 10 kW

Weight : 550 kg

Closing Operation : 15 - 25 seconds

Outer Body : Stainless Steel AISI304

Warranty : 2 Years

Certificate: CE

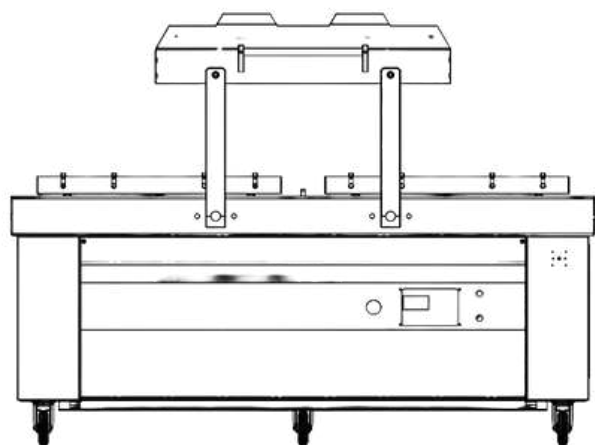
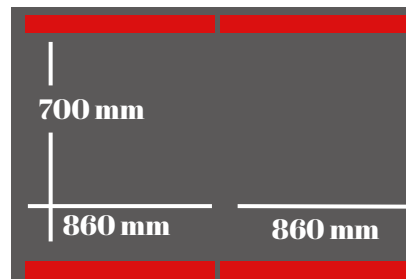

Double Chamber Models **W72**



Machine Dimensions : 1065 x 1790 x 1100 h mm

Chamber Size : 840 x 860 x 220 h mm

Pump Capacity : 105 m³ / h (151 m³ Opt.)

Sealing Bar : 4 x 720 mm

Power : 3P+N+PE 380V 50/60Hz

kW: 3.5 - 4.5 kW

Weight : 450 kg

Closing Operation : 15 - 25 seconds

Outer Body : Stainless Steel AISI304

Warranty : 2 Years

Certificate: CE

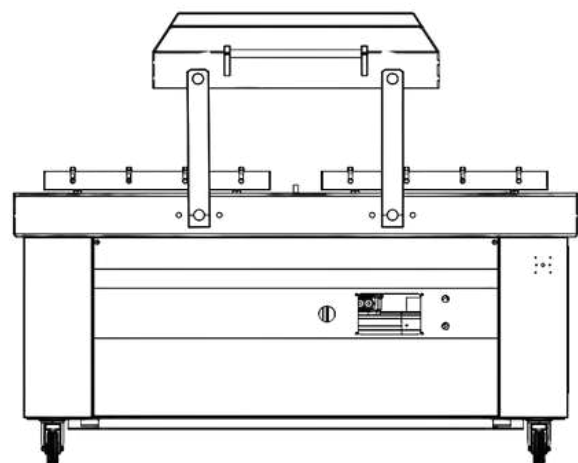
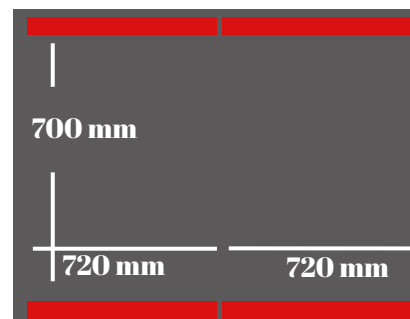



Machine Dimensions : 965 x 1460 x 1100 h mm

Chamber Size : 770 x 720 x 220 h mm

Pump Capacity : 105 m³ / h (151 m³ Opt.)

Sealing Bar : 4 x 550 mm

Power : 3P+N+PE 380V 50Hz

kW: 3.5 - 4.5 kW

Weight : 350 kg

Closing Operation : 15 - 25 seconds

Outer Body : Stainless Steel AISI304

Warranty : 2 Years

Certificate: CE

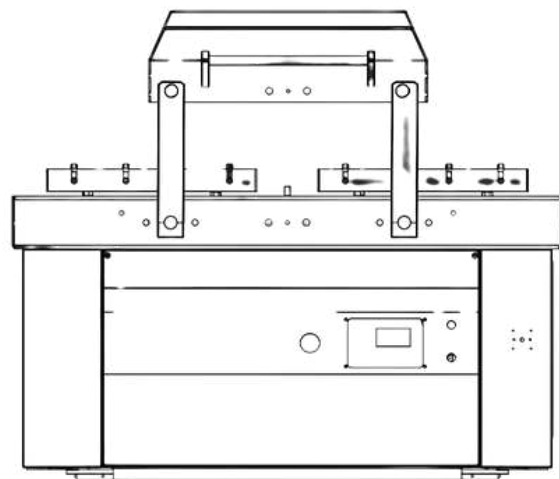
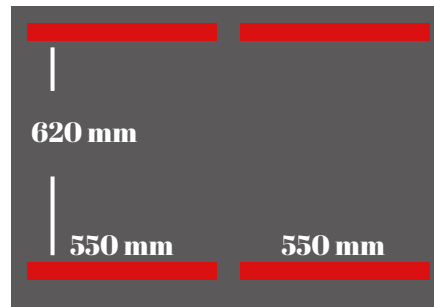

volvac

Double Chamber Pro Models

Package your everyday products quickly and with the highest quality, effortlessly and practically!



All Electrical Components are World Brands and 2 years under the warranty (Mainly Schneider, Siemens)

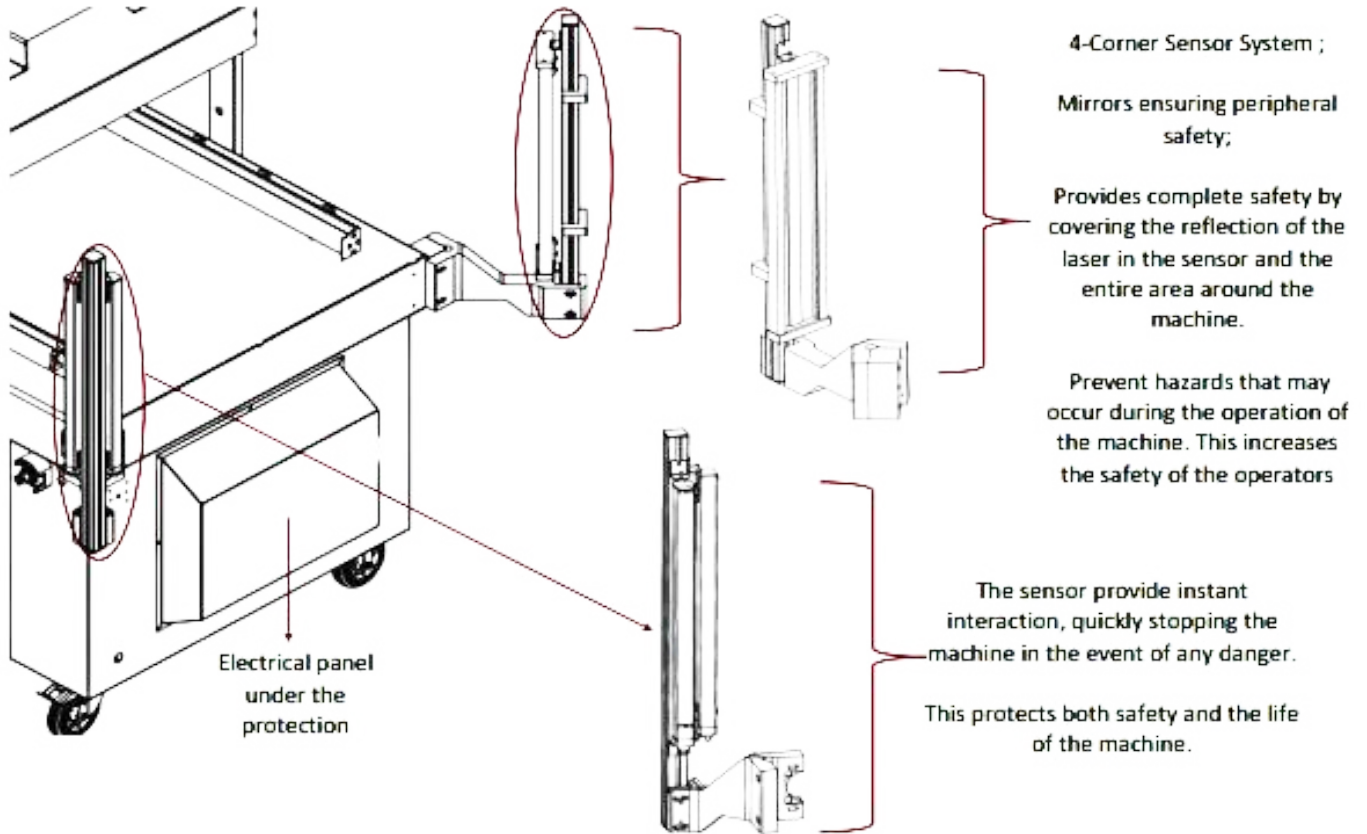

→ Stable 7" Scheider Touch Control Screen

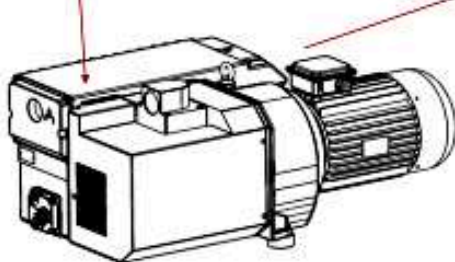

Using Italian Vacuum Pump (DVP or GEV) also according to customer request BUSCH brand as an Optional

Pump Capacity between 105 m³/h to 300m³/h

The Red (Oxygen) Pump for Fresh Meat in MAP as an optional

High strong pumping (0.01 mbar vacuum value)



Floor Standing W104



Machine Dimensions : 960 x 1175 x 1130 h mm

Chamber Size : 752 x 1068 x 180 h mm

Pump Capacity : 105 m³ / h (151 m³ Opt.)

Sealing Bar : 2 x 680 mm - 1040 mm

Power : 3P+N+PE 380V 50/60Hz

kW : 5 - 7.5 kW

Weight : 360 kg

Closing Operation : 15 - 25 seconds

Outer Body : Stainless Steel AISI304

Warranty : 2 Years

Certificate: CE

550 mm

1040 mm

550 mm

1040 mm

550 mm

1040 mm



Machine Dimensions : 675 x 775 x 1030 h mm

Chamber Size : 540 x 712 x 130 h mm

Pump Capacity : 45 m³ / h (65 m³ Opt.)

Sealing Bar : 2 x 680 mm

Power : 3P+N+PE 380V 50/60Hz

kW : 2.5 kW

Weight : 162 kg

Closing Operation : 15 - 25 seconds

Outer Body : Stainless Steel AISI304

Warranty : 2 Years

Certificate: CE

680 mm

485 mm

680 mm

Floor Standing **W52**



Machine Dimensions : 675 x 775 x 1030 h mm

Chamber Size : 540 x 712 x 130 h mm

Pump Capacity : 45 m³ / h (65 m³ Opt.)

Sealing Bar : 2 x 520 mm

Power : 3P+N+PE 380V 50/60Hz

kW : 2.5 kW

Weight : 159 kg

Closing Operation : 15 - 25 seconds

Outer Body : Stainless Steel AISI304

Warranty : 2 Years

Certificate: CE

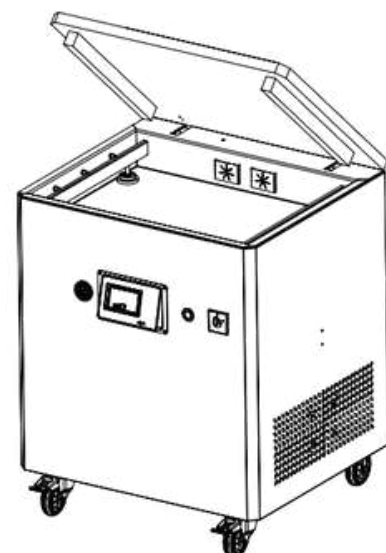
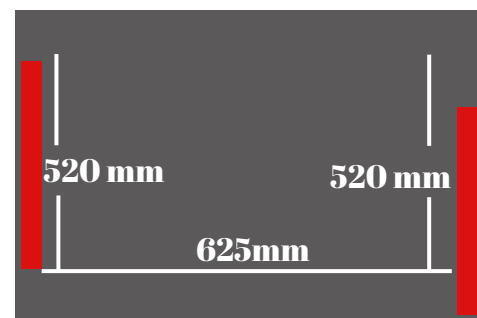



- Machine Dimensions : 631 x 585 x 1015 h mm
- Chamber Size : 497 x 522 x 130 h mm
- Pump Capacity : 21 m³ / h (45 m³ Opt.)
- Sealing Bar : 510 mm
- Power : 220 volt 50/60 Hz
- kW : 2 kW - 2.5 kW
- Weight : 122 kg
- Closing Operation : 15 - 25 seconds
- Outer Body : Stainless Steel AISI304
- Warranty : 2 Years
- Certificate: CE

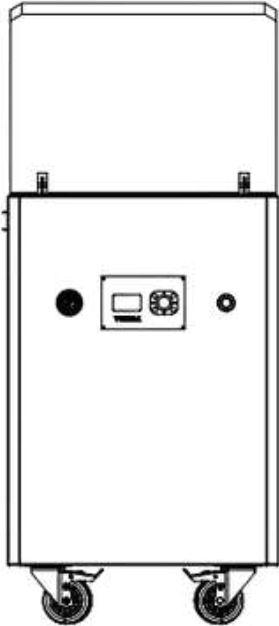
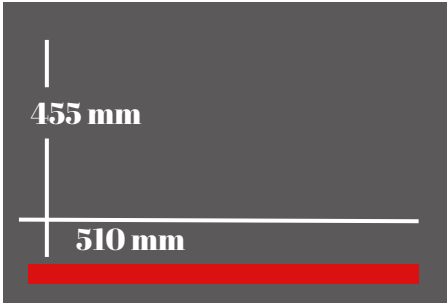

Floor Standing **W48H**



Machine Dimensions : 631 x 585 x 900 h mm

Chamber Size : 497 x 522 x 130 h mm

Pump Capacity : 21 m³ / h (45 m³ Opt.)

Sealing Bar : 2 x 480 mm

Power : 220 volt 50/60 Hz

kW: 2 kW - 2.5 kW

Weight : 122 kg

Closing Operation : 15 - 25 seconds

Outer Body : Stainless Steel AISI304

Warranty : 2 Years

Certificate: CE

480 mm

430 mm

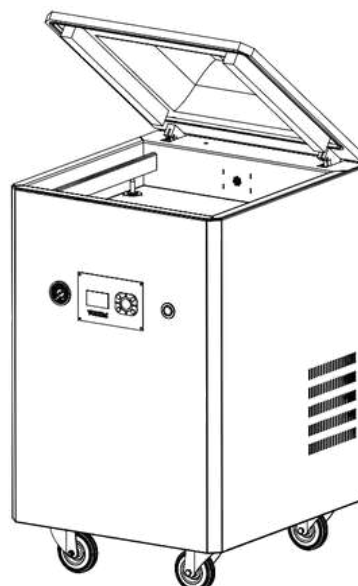



Machine Dimensions : 631 x 585 x 480 h mm

Chamber Size : 497 x 522 x 190 h mm

Pump Capacity : 21 m³ / h

Sealing Bar : 510 mm

Power : 220 volt 50/60 Hz

kW: 2 kW

Weight : 104 kg

Closing Operation : 15 - 25 seconds

Outer Body : Stainless Steel AISI304

Warranty : 2 Years

Certificate: CE

455 mm

510 mm

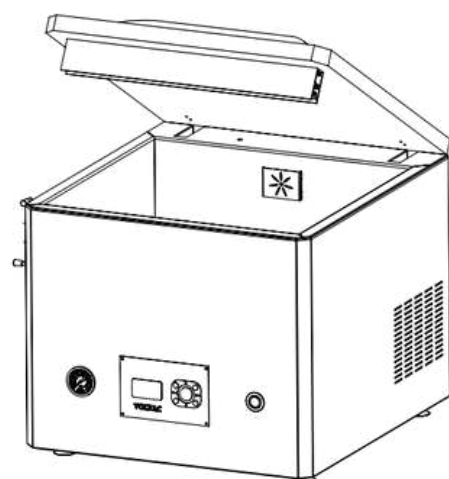

Table Top Models **W51**



Machine Dimensions : 630 x 585 x 480 h mm

Chamber Size : 497 x 522 x 130 h mm

Pump Capacity : 21 m³ / h

Sealing Bar : 510 mm

Power : 220 volt 50/60 Hz

kW: 2 kW

Weight : 95 kg

Closing Operation : 15 - 25 seconds

Outer Body : Stainless Steel AISI304

Warranty : 2 Years

Certificate: CE

455 mm

510 mm

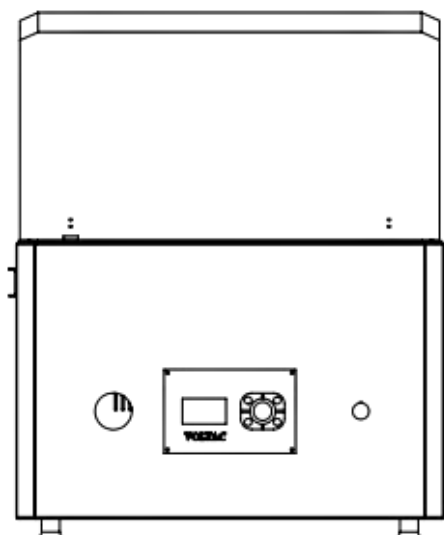



Machine Dimensions 630 x 585 x 475 h mm

Chamber Size : 497 x 522 x 130 h mm

Pump Capacity 21 m³ / h

Sealing Bar : 2 x 480 mm

Power : 220 volt 50/60 Hz

kW: 2 kW

Weight : 95 kg

Closing Operation : 15 - 25 seconds

Outer Body : Stainless Steel AISI304

Warranty : 2 years

Certificate: CE

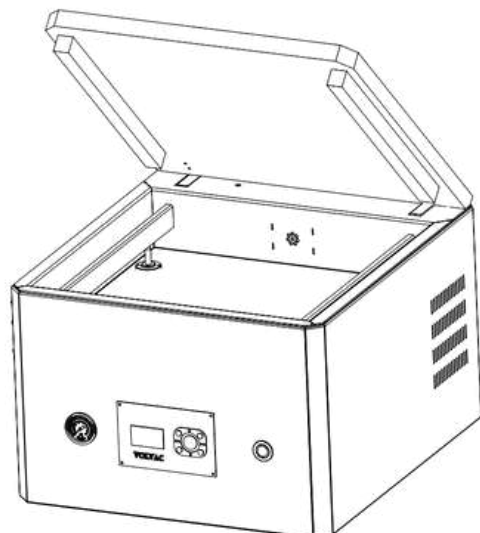
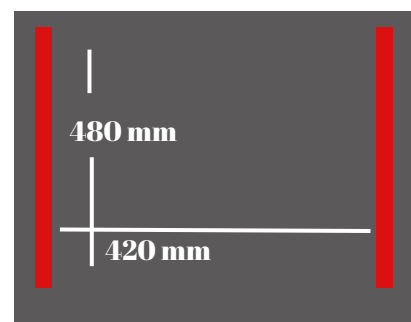

Table Top Models **W42**



Machine Dimensions : 568 x 500 x 452 h mm

Chamber Size : 437 x 434 x 130 h mm

Pump Capacity : 21 m³ / h

Sealing Bar : 2 x 420 mm

Power : 220 volt 50/60 Hz

kW : 1.5 kW

Weight : 62 kg

Closing Operation : 15 - 25 seconds

Outer Body : Stainless Steel AISI304

Warranty : 2 Years

Certificate: CE

310 mm

420 mm

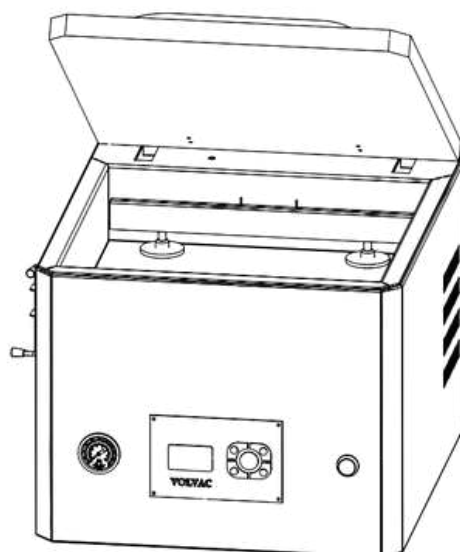

Table Top Models **W35ML**



Machine Dimensions : 510 x 763 x 475 h mm

Chamber Size : 700 x 375 x 160 h mm

Pump Capacity : 21 m³ / h

Sealing Bar : 2 x 350 mm

Power : 220 volt 50/60 Hz

kW 1.5 kW

Weight : 80 kg

Closing Operation : 15 - 25 seconds

Outer Body : Stainless Steel AISI304

Warranty : 2 Years

Certificate: CE

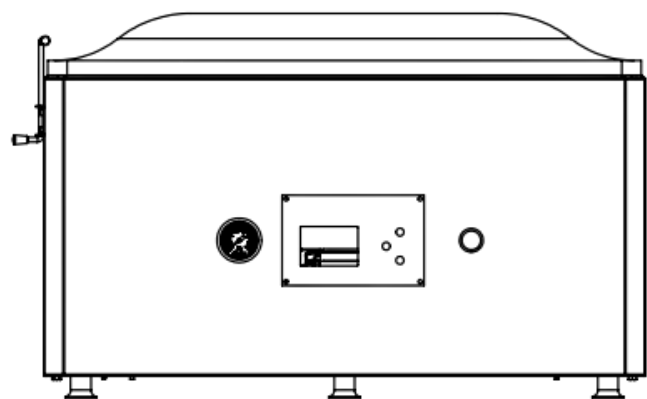
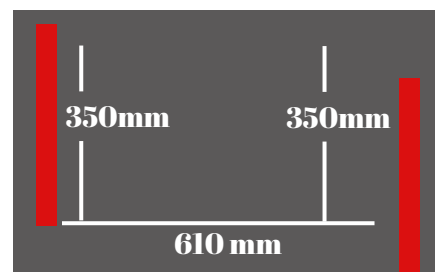

Vertical Model W700



Machine Dimensions : 1700 x 1725 x 1410 h mm

Chamber Size : 890 x 850 x 255 h mm

Pump Capacity : 151 m³ / h

Sealing Bar : 2 x 700 mm

Power : 3P+N+PE 380V 50/60Hz

kW: 3.5 - 4.5 kW

Weight : 600 kg

Closing Operation : 15 - 25 seconds

Outer Body : Stainless Steel AISI304

Warranty : 2 Years

Certificate: CE

DIP TANK MACHINES





 **VOLVAC-DT480**

 **VOLVAC-DT650**





Machine Dimensions : 671 x 1233 x 1340 h

Dipping Platform Dimensions: 450x600mm

Stroke Dipping Table : 300mm

Max Product Height : 300mm

Stainless Steel Dipping Platform : Standard

Water Content Capacity : 95 liter

Max Product Weight : 30 kg

Power Lifting Platform : Pneumatic

Stainless Steel Cover : Standard

Dip Time Controller : Standard

Temperature Control : Automatic

Cycle Time : 3 - 4 seconds

Outer Body : Stainless Steel AISI304

Power Supply : 400 - 3 - 50/60 Hz

Voltage : 7,5 kW - 10 kW

Warranty : 2 Years

Certificate : CE

Dip Tank Models DT-650



Machine Dimensions : 771 x 1233 x 1340 h

Dipping Platform Dimensions : 550x700

Stroke Dipping Table : 300 mm

Max Product Height : 350 mm

Stainless Steel Dipping Platform : Standard

Water Content Capacity : 125 liter

Max Product Weight : 35 kg

Power Lifting Platform : Pneumatic

Stainless Steel Cover : Standard

Dip Time Controller : Standard

Temperature Control : Automatic

Cycle Time : 3 - 4 seconds

Outer Body : Stainless Steel AISI304

Power Supply : 400 - 3 - 50/60 Hz

Voltage : 7,5 kW - 15 kW

Warranty : 2 Years

Certificate : CE



AUTOMATIC SLICER MACHINE



 **VOLVAC-S20**





Machine Dimensions : 1500 x 1300 x 750 mm

Chamber Size : 180 x 120 mm

Cycle: Between 1 mm to 40 mm

Capacity : 250 silices/minute

Power : 3P+N+PE 380V 50/60Hz

kW: 1,5 kW

Pneumatic Feeding : 16 NI/6-8 bar

Memory : 99 Piece

Outer Body : Stainless Steel AISI304

Warranty : 2 Years

Certificate: CE



vol



volc

volvac

PACKAGING SOLUTIONS

**VOLVAC PAKETLEME VE GIDA
MAKİNALARI SAN. TİC. LTD. ŞTİ.**

**Sanayi District Ensar Street No: 3/1
Pendik, Istanbul**

Phone : 0216 441 10 72

E-Mail : info@volvac.com.tr

**VOLVAC GERMANY
(OFFICE)**

**Ikarusallee 15, 30179
Hannover, Almanya**

Phone : +49 163 263 39 94

E-Mail : info@volvacgermany.de

